



# MR. PLAY WOOD

GIFT FOR  
GIFTED

**156**  
ДЕТАЛІ  
PARTS

ІНСТРУКЦІЯ  
USER GUIDE

## Mechanical Unicorn

NAME Механічний Єдиноріг  
Механічний конструктор із дерева

TYPE



100%  
ДЕРЕВО  
/WOOD

14+

ВІК  
/AGE



ДЛЯ ВСІЄЇ  
РОДИНИ  
/FAMILY  
FRIENDLY



БЕЗ КЛЕЮ  
/NO GLUE

SPECIFICATIONS

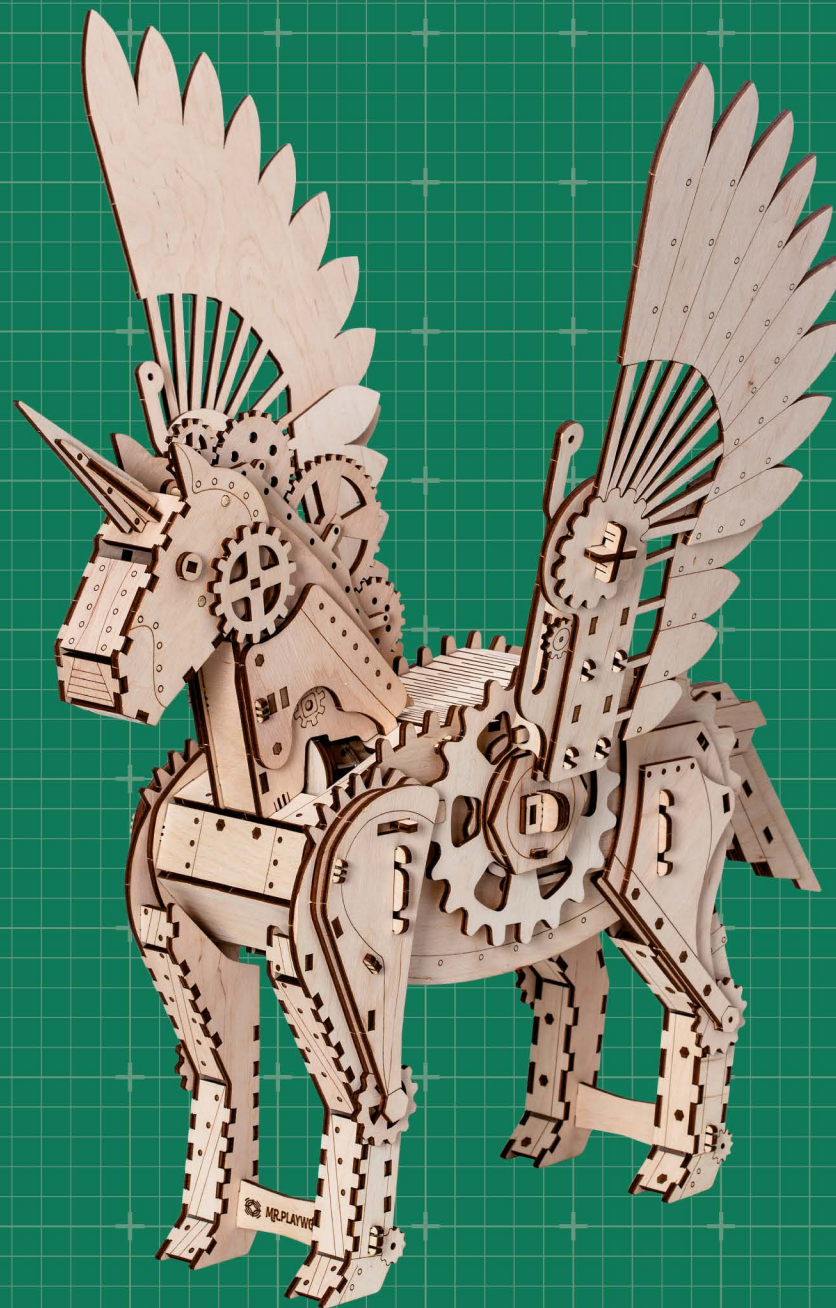



**ІНСТРУКЦІЯ ПО ВИКОРИСТАННЮ. UKR.** У ВАШИХ РУКАХ ЧАРИВНИЙ МЕХАНІЧНИЙ КОНСТРУКТОР ВІД MR. PLAYWOOD, ЙОГО НЕОБХІДНО ЗІБРАТИ З ДЕТАЛЕЙ, ЯКІ ВІД'ЄДНУЮТЬСЯ ВІД ПЛАНШЕТИВ І ЗБИРАЮТЬСЯ БЕЗ КЛЕЮ. ВСЕ, ЩО ВАМ НЕОБХІДНО ДЛЯ ЦЬОГО - Є В КОРОБЦІ, ВИКОРИСТОВУЙТЕ ВІСК ДЛЯ ПОЛІПШЕННЯ КОВЗАННЯ ДЕТАЛЕЙ МЕХАНІЗМІВ І ЛЕГКОЇ СТИКОВКИ ДРІБНИХ ДЕТАЛЕЙ. ВИКОНУЙТЕ ЗБІРКУ ВІДПОВІДНО ДО ІНСТРУКЦІЇ. ДЛЯ СПРОЩЕННЯ ЗБІРКИ, В КОЖНОМУ КОНСТРУКТОРІ ЗАПРОПОНОВАНИЙ УНІВЕРСАЛЬНИЙ ІНСТРУМЕНТ, ВИКОРИСТОВУЙТЕ ЙОГО ДЛЯ ВІД'ЄДНАННЯ ДЕТАЛЕЙ З ПЛАНШЕТИВ, ОДЯГАННЯ ШЕСТЕРЕНЬ НА ОСІ І ВИМІРЮВАНЬ ДОВЖИН.

**GUÍA DEL USUARIO. SPA.** TIENE EN SUS MANOS EL MECANO MECÁNICO MÁGICO DEL MR. PLAYWOOD, DEBE SER MONTADO DE LAS PIEZAS QUE SE EXPRESAN FUERA DE LA TABLA Y SE RECOGEN SIN EL PEGAMENTO. TODO LO QUE NECESITA PARA EL MONTAJE ESTÁ EN LA CAJA, USE LA CERA PARA MEJORAR EL DESLIZAMIENTO DE LAS PIEZAS DE LOS MECANISMOS Y EL ENSAMBLAJE FÁCIL DE LOS ELEMENTOS PEQUEÑOS. EJECUTE EL MONTAJE DE ACUERDO CON LA GUÍA. PARA SIMPLIFICAR EL MONTAJE, EN CADA MECANO SE PROPONE UN INSTRUMENTO UNIVERSAL, ÚSELO PARA EXPRESAR LAS PIEZAS DE LA TABLA, FIJAR ENGRANAJES EN EL EJE Y MEDIR LA LONGITUD.

**USER GUIDE. ENG.** YOU HOLD A MAGIC MECHANIC CONSTRUCTION KIT FROM MR.PLAYWOOD, IT SHOULD BE BUILT WITHOUT GLUE, FROM PARTS PRESSED OUT OF A HOLDERS. ALL YOU NEED FOR THE ASSEMBLY IS IN THE BOX. USE WAX TO IMPROVE SLIDING OF WORKING PARTS AND EASE COUPLING OF SMALL PARTS. ASSEMBLE ACCORDING TO THE GUIDE. TO EASE THE ASSEMBLY, EACH CONSTRUCTION KIT COMPRISES A VERSATILE TOOL. USE IT TO PRESS PARTS OUT OF A HOLDERS, PUT SPROCKETS ON AXES AND MEASURE LENGTHS.

**INSTRUKCJE UŻYCIA. POL.** MASZ W RĘKACH MAGICZNE KLOCKI MECHANICZNE OD MR. PLAYWOOD, KTÓRE TRZEBA SKŁADAĆ BEZ UŻYCIA KLEJU Z CZĘŚCI WYCISKANYCH Z PŁYTY. ZESTAW MA WSZYSTKIE CZĘŚCI POTRZEBNE DO SKŁADANIA. DLA POLEPSZENIA POŚLIZGU ELEMENTÓW MECHANIZMU I ŁATWEGO DOPASOWANIA MAŁYCH CZĘŚCI NALEŻY UŻYWAĆ WOSKU. SKŁADANIE WYKONUJE SIĘ ZGODNIE Z INSTRUKCJAMI. ABY UPROŚCIĆ SKŁADANIE, KAŻDY ZESTAW KLOCKÓW ZAWIERA UNIWERSALNE NARZĘDZIE, KTÓREGO TRZEBA UŻYWAĆ DO WYCISKANIA CZĘŚCI Z PŁYTY, UMIESZCZENIA NA OSI KÓŁ ZĘBATYCH ALBO POMIARU DŁUGOŚCI.

**ИНСТРУКЦИЯ ПО ИСПОЛЬЗОВАНИЮ. RUS.** В ВАШИХ РУКАХ ВОЛШЕБНЫЙ МЕХАНИЧЕСКИЙ КОНСТРУКТОР ОТ MR.PLAYWOOD, ЕГО НЕОБХОДИМО СОБРАТЬ ИЗ ДЕТАЛЕЙ, КОТОРЫЕ ИЗВЛЕКАЮТСЯ ИЗ ПЛАНШЕТОВ И СОБИРАЮТСЯ БЕЗ КЛЕЯ. ВСЕ, ЧТО ВАМ НЕОБХОДИМО ДЛЯ СБОРКИ НАХОДИТСЯ В КОРОБКЕ, ИСПОЛЬЗУЙТЕ ВОСК ДЛЯ УЛУЧШЕНИЯ СКОЛЬЖЕНИЯ ДЕТАЛЕЙ МЕХАНИЗМОВ И ЛЕГКОЙ СТЫКОВКИ МЕЛКИХ ЧАСТЕЙ. ИСПОЛНЯЙТЕ СБОРКУ В СООТВЕТСТВИИ С ИНСТРУКЦИЕЙ. ДЛЯ УПРОЩЕНИЯ СБОРКИ, В КАЖДОМ КОНСТРУКТОРЕ ПРЕДЛОЖЕН УНИВЕРСАЛЬНЫЙ ИНСТРУМЕНТ, ИСПОЛЬЗУЙТЕ ЕГО ДЛЯ ИЗВЛЕЧЕНИЯ ДЕТАЛЕЙ ИЗ ПЛАНШЕТОВ, ОДЕВАНИЯ ШЕСТЕРЕНOK НА ОСИ И ИЗМЕРЕНИЙ ДЛИНЫ.

**CONSEILS D'UTILISATION. FRA.** VOUS TENEZ ENTRE VOS MAINS LE MERVEILLEUX JEU DE CONSTRUCTION MÉCANIQUE DE MR. PLAYWOOD QUI PEUT ÊTRE ASSEMBLÉ AVEC DES PIÈCES DÉGAGÉES DES PLANCHETTES ET MONTÉES SANS COLLE. LA BOÎTE CONTIENT TOUT CE QU'IL VOUS FAUT POUR L'ASSEMBLAGE, UTILISEZ LA CIRE POUR AMÉLIORER LE GLISSEMENT DES DÉTAILS DES MÉCANISMES ET FACILITER LE RACCORDEMENT DES PETITES PIÈCES. EFFECTUEZ L'ASSEMBLAGE CONFORMÉMENT AUX CONSEILS D'UTILISATION. POUR FACILITER L'ASSEMBLAGE, CHAQUE BOÎTE CONTIENT UN OUTIL UNIVERSEL, UTILISEZ-LE POUR DÉGAGER DES PIÈCES DES PLANCHETTES, MONTER DES ENGRENAGES SUR LES AXES ET MESURER LA LONGUEUR.



**ГЕБРАУХСАНВЕISUNG. DEU.** SIE HALTEN IN IHREN HÄNDEN DEN ZAUBERHAFTEN MECHANISCHEN BAUKASTEN VON MR. PLAYWOOD, ER MUSS AUS TEILEN ZUSAMMENGEBAUT WERDEN, WELCHE AUS DEM BRETT GEDRÜCKT UND OHNE LEIM ZUSAMMENGESTELLT WERDEN. ALLES, WAS SIE FÜR DEN ZUSAMMENBAU BRAUCHEN, BEFINDET SICH IM KATEN; VERWENDEN SIE DAS WACHS, DAMIT DIE BAUELEMENTE VON MECHANISMEN BESSER GLEITEN UND DAMIT DIE KLEINEN ELEMENTE LEICHTER ZUSAMMENGEBAUT WERDEN. DER ZUSAMMENBAU SOLL IN ÜBEREINSTIMMUNG MIT DER GEBRAUCHSАНВЕISUNG DURCHGEFÜHRT WERDEN. DAMIT DER ZUSAMMENBAU EINFACHER WÄRE, WIRD IN JEDEM BAUKASTEN EIN UNIVERSALWERKZEUG ANGEBOТEN, VERWENDEN SIE ES, UM DIE BAUELEMENTE AUS DEM BRETT ZU DRÜCKEN, DIE ZAHNRÄDER AUF DIE АХSЕН ZU SETZEN UND DIE LÄNGE ZU MESSEN.

**UKR.** ЗАПАЧИ ДЕТАЛІ. **ENG.** SPARE PARTS. **RUS.** ЗАПАСНЫЕ ДЕТАЛИ **DEU.** ERSATZTEILE **POL.** CZĘŚCI ZAMIENNE **FRA.** PIÈCES DE RECHANGE **SPA.** PIEZAS DE REPUESTO.

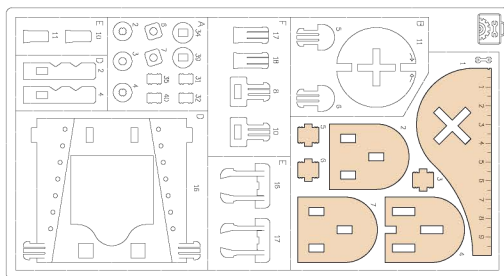

**UKR.** ОБЕРЕЖНО! МАТЕРІАЛ КОНСТРУКТОРА - ДЕРЕВО, МОЖЛИВІ МІКРОТРИЩИНИ, ВИКОРИСТОВУЙТЕ ІНСТРУМЕНТ, ЩОБ УНИКНУТИ РОЗЛОМУ ДЕТАЛЕЙ ПРИ ВИЛУЧЕННІ З ПЛАНШЕТА. **ENG.** BE CAREFUL! CONSTRUCTION KIT MATERIAL IS WOOD. MICRO-CRACKS ARE POSSIBLE. USE THE TOOL TO AVOID CRACK OF PARTS WHEN REMOVING FROM THE HOLDER. **RUS.** ОСТОРОЖНО! МАТЕРІАЛ КОНСТРУКТОРА - ДЕРЕВО, ВОЗМОЖНЫ МІКРОТРЕЩИНЫ, ИСПОЛЬЗУЙТЕ ИНСТРУМЕНТ ВО ИЗБЕЖАНИЕ РАЗЛОМА ДЕТАЛЕЙ ПРИ ИЗВЛЕЧЕНИИ ИЗ ПЛАНШЕТА. **DEU.** VORSICHT! DAS MATERIAL DES BAUKASTENS IST HOLZ, ES SIND DIE MIKRO-RISSE MÖGLICH, VERWENDEN SIE DAS WERKZEUG, UM DEN BRUCH VON BAUELEMENTEN BEI DER HERAUSNAHME AUS DEM BRETT ZU VERMEIDEN. **POL.** UWAGA! KLOCKI SĄ ZROBIONE Z DREWNA, WIĘC MOŻLIWE SĄ MIKROPEKNIĘCIA. PRZY WYJMOWANIU CZĘŚCI Z DESKI NALEŻY UŻYWAĆ NARZĘDZIA, ABY UNIKNĄĆ ICH ZERWANIA. **FRA.** AVERTISSEMENT! LE JEU DE CONSTRUCTION ÉTANT FAIT EN BOIS, LA POSSIBILITÉ D'APPARITION DE MICROFISSURES N'EST PAS EXCLUE, UTILISEZ L'OUTIL SPÉCIAL POUR ÉVITER DE BRISER LES PIÈCES EN LES DÉGAGEANT DES PLANCHETTES. **SPA.** ¡CUIDADO! EL MATERIAL DEL MECANO ES MADERA, LAS MICROFISURAS SON POSIBLES, UTILICE EL INSTRUMENTO PARA EVITAR LA ROTURA DE LAS PIEZAS AL SACAR DE LA PLANCHETA.

**UKR.** ІНСТРУМЕНТ **ENG.** THE TOOL **RUS.** ИНСТРУМЕНТ **DEU.** WERKZEUG **POL.** NARZĘDZIE **FRA.** OUTIL **UNIVERSEL** **SPA.** INSTRUMENT

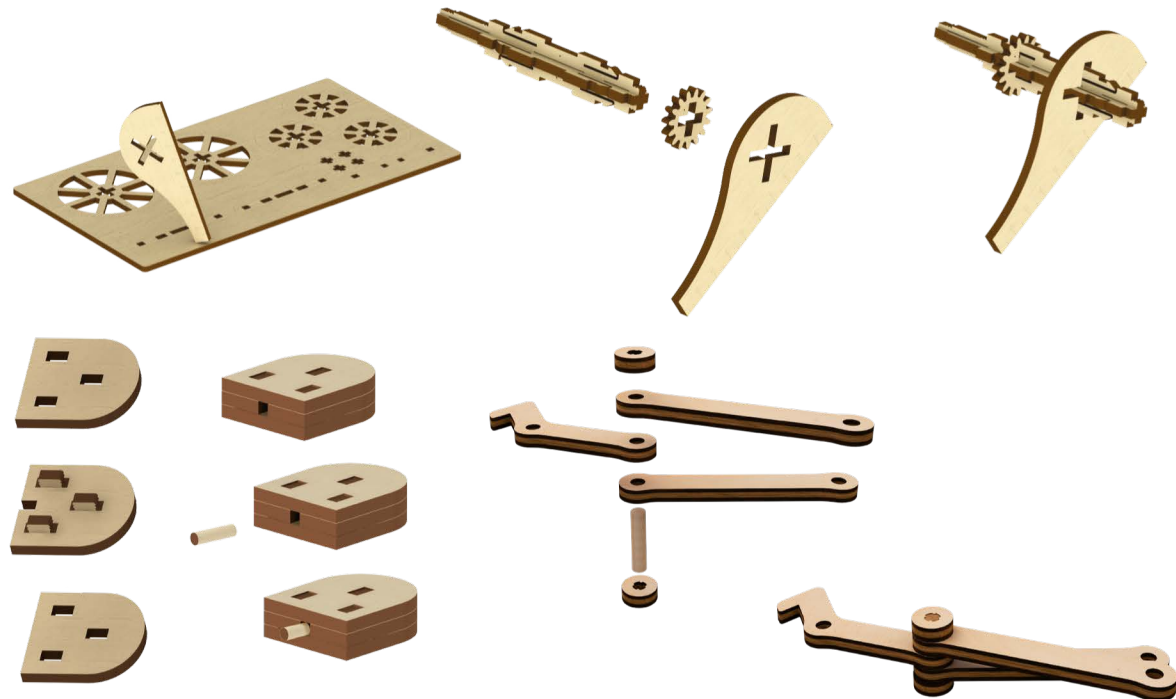

**UKR.** УВАГА! ЗВЕРНІТЬ УВАГУ НА УМОВНІ ПОЗНАЧЕННЯ ІНСТРУКЦІЇ **ENG.** CAUTION! TAKE A NOTE OF GUIDE LEGEND **RUS.** ВНИМАНИЕ! ОБРАТИТЕ ВНИМАНИЕ НА УСЛОВНЫЕ ОБОЗНАЧЕНИЯ ИНСТРУКЦИИ **DEU.** ACHTUNG! BEACHTEN SIE DIE KURZZEICHEN IN DER GEBRAUCHSANWEISUNG **POL.** UWAGA! PROSIMY ZWRÓCIĆ UWAGĘ NA SYMBOLE INSTRUKCJI **FRA.** ATTENTION! VEUILLEZ RESPECTER LES CONSEILS D'UTILISATIONS PRÉSENTÉS PAR LES PICTOGRAMMES **SPA.** ¡ATENCIÓN! PRESTE ATENCIÓN A LOS SÍMBOLOS DE LA GUÍA



**UKR.** ЗМАЩУЙТЕ ДЕТАЛІ ВОСКОМ **ENG.** GREASE PARTS WITH WAX **RUS.** СМАЗЫВАЙТЕ ДЕТАЛИ ВОСКОМ **DEU.** SCHMIEREN SIE DIE BAUELEMENTE MIT WACHS **POL.** SMARUJ CZĘŚCI WOSKIEM **FRA.** LUBRIFIEZ LES PIÈCES AVEC DE LA CIRE **SPA.** LUBRICAR LAS PIEZAS CON CERA



**UKR.** ОБОВ'ЯЗКОВО ЗМАСТИТИ ВОСКОМ ПО ХОДУ ЧЕРВОНОЇ ЛІНІЇ **ENG.** MAKE SURE YOU GREASE WITH WAX ALONG THE RED LINE **RUS.** ОБЯЗАТЕЛЬНО СМАЗАТЬ ВОСКОМ ПО ХОДУ КРАСНОЙ ЛИНИИ **DEU.** SCHMIEREN SIE DEN BEREICH DIE ROTE LINIE ENTLANG UNBEDINGT MIT WACHS **POL.** ZAWSZE SMARUJ WOSKIEM WZDŁUŻ BIEGU CZERWONEJ LINII **FRA.** LA PIÈCE DOIT ÊTRE LUBRIFIÉE AVEC DE LA CIRE SUIVANT LA LIGNE ROUGE **SPA.** SIEMPRE LUBRICAR CON CERA A LO LARGO DE LA LÍNEA ROJA



**UKR.** ЗВЕРНІТЬ УВАГУ **ENG.** PAY ATTENTION **RUS.** ОБРАТИТЕ ВНИМАНИЕ **DEU.** BEACHTEN SIE **POL.** ZWRÓĆ UWAGĘ **FRA.** ATTENTION **SPA.** PRESTAR ATENCIÓN



**UKR.** УВАГУ СЮДИ **ENG.** ATTENTION HERE **RUS.** ВНИМАНИЕ СЮДА **DEU.** ACHTEN SIE DARAUF **POL.** ZWRÓĆ UWAGĘ TUTAJ **FRA.** ATTENTION PARTICULIÈRE À CE POINT **SPA.** ATENCIÓN AQUÍ



**UKR.** ЗБЕРІТЬ ДРУГИЙ ТАКИЙ ЖЕ ВУЗОЛ, ЗГІДНО З ІНСТРУКЦІЄЮ **ENG.** ASSEMBLE ANOTHER SIMILAR UNIT ACCORDING TO THE GUIDE **RUS.** СОБЕРИТЕ ВТОРОЙ ТАКОЙ ЖЕ УЗЕЛ, СОГЛАСНО ИНСТРУКЦИИ **DEU.** BAUEN SIE DIE ZWEITE GLEICHE BAUGRUPPE IN ÜBEREINSTIMMUNG MIT DER GEBRAUCHSANWEISUNG **POL.** ZŁÓŻ DRUGI TOŻSAMY ZESPÓŁ ZGODNIE Z INSTRUKCJĄ **FRA.** ASSEMBLER LE DEUXIÈME ENSEMBLE IDENTIQUE SUIVANT LES CONSEILS **SPA.** ENSAMBLAR EL SEGUNDO BLOQUE IGUAL DE ACUERDO CON LA GUÍA.



**UKR.** РОЗМІР ДЕТАЛІ В ММ (1 ДЮЙМ = 25,4 ММ) **ENG.** PART SIZE IN MM (1 INCH = 25.4 MM) **RUS.** РАЗМЕР ДЕТАЛИ В ММ (1 ДЮЙМ = 25,4 ММ) **DEU.** GRÖÖE DES BAUELEMENTS IN MM (1 DAUMEN = 25,4 MM) **POL.** ROZMIAR ELEMENTU W MM (1 CAL = 25,4 MM) **FRA.** DIMENSIONS DE LA PIÈCE EN MM (1 POUCE = 25,4 MM) **SPA.** TAMAÑO DE LA PIEZA EN MM (1 PULGADA = 25.4 MM)





MR.  
PLAY  
WOOD

GIFT FOR  
GIFTED



**UKR.** СКРУТИТЬ ДЕТАЛЬ **ENG.** SCREW A PART OFF **RUS.** СВЕРНИТЕ ДЕТАЛЬ **DEU.** DREHEN SIE DAS BAUELEMENT AB. **POL.** SKRĘĆ ELEMENT **FRA.** ROULER LA PIÈCE **SPA.** TIRAR LA PIEZA



**UKR.** СХЕМА ЗБИРКИ **ENG.** SCHEMATIC ASSEMBLY **RUS.** СХЕМА СБОРКИ **DEU.** SCHALTUNGSANORDNUNG **POL.** SCHEMATYCZNY MONTAŻ **FRA.** NOTICE DE MONTAGE **SPA.** MONTAJE ESQUEMÁTICO



**UKR.** ВСТАНОВИТИ ДЕТАЛЬ У ВКАЗАНЕ МІСЦЕ **ENG.** SET A PART INTO SPECIFIED POSITION **RUS.** УСТАНОВИТЬ ДЕТАЛЬ В УКАЗАННОЕ МЕСТО **DEU.** DAS BAUELEMENT AN DIE ANGEGEBENE STELLE EINSTELLEN **POL.** ZAINSTALUJ CZĘŚĆ W OKREŚLONYM MIEJSCU **FRA.** MONTER LA PIÈCE AU POINT INDiqué **SPA.** INSTALAR LA PIEZA EN EL LUGAR ESPECIFICADO



**UKR.** ВСТАВИТИ ДЕТАЛЬ, ПРОВЕРТАЮЧИ (ВКРУТИТИ) **ENG.** INSERT A PART WITH ROTATION (SCREW IN) **RUS.** УСТАНОВИТЬ ДЕТАЛЬ, ПРОКРУЧИВАЯ (ВКРУТИТЬ) **DEU.** DAS BAUELEMENT DREHEND EINSTECKEN (EINDREHEN). **POL.** WŁÓŻ CZĘŚĆ POPRZEZ OBRÓT (WŚRUBUJ) **FRA.** INSÉRER UNE PIÈCE EN LA TOURNANT (VISSER) **SPA.** INSERTAR LA PIEZA, GIRANDO (ATORNILLAR)



**UKR.** ПЕРЕВІРИТИ ПРАЦЕЗДАТНІСТЬ МЕХАНІЗМУ **ENG.** CHECK OPERATION **RUS.** ПРОВЕРИТЬ РАБОТСПОСОБНОСТЬ МЕХАНИЗМА **DEU.** DIE BETRIEBSFÄHIGKEIT DES MECHANISMUS ÜBERPRÜFEN **POL.** SPRAWDŹ DZIAŁANIE MECHANIZMU **FRA.** VÉRIFIER LE FONCTIONNEMENT DU MÉCANISME **SPA.** VERIFICAR LA FUNCIONALIDAD DEL MECANISMO



**UKR.** ЗАПАСНІ ДЕТАЛІ **ENG.** SPARE PARTS **RUS.** ЗАПАСНЫЕ ДЕТАЛИ **DEU.** ERSATZTEILE **POL.** CZĘŚCI ZAMIENNE **FRA.** PIÈCES DE RECHANGE **SPA.** PIEZAS DE REPUESTO



**UKR.** ІНСТРУМЕНТ **ENG.** THE TOOL **RUS.** ИНСТРУМЕНТ **DEU.** WERKZEUG **POL.** NARZĘDZIE **FRA.** OUTIL UNIVERSEL **SPA.** INSTRUMENTO

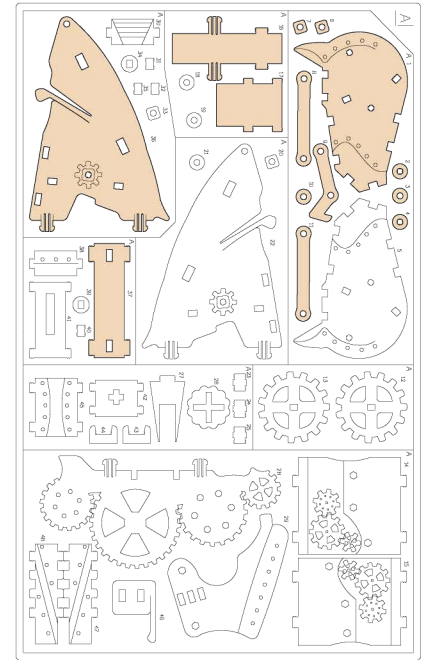
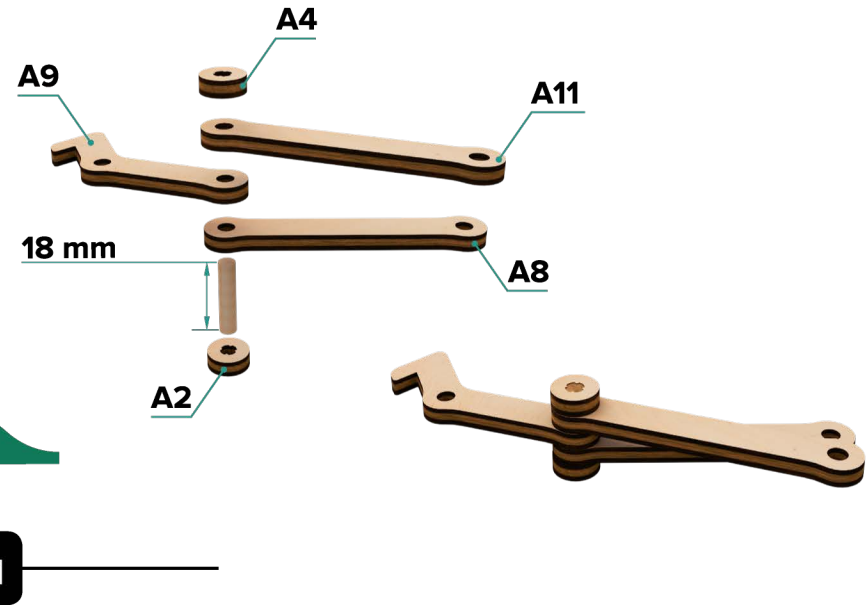
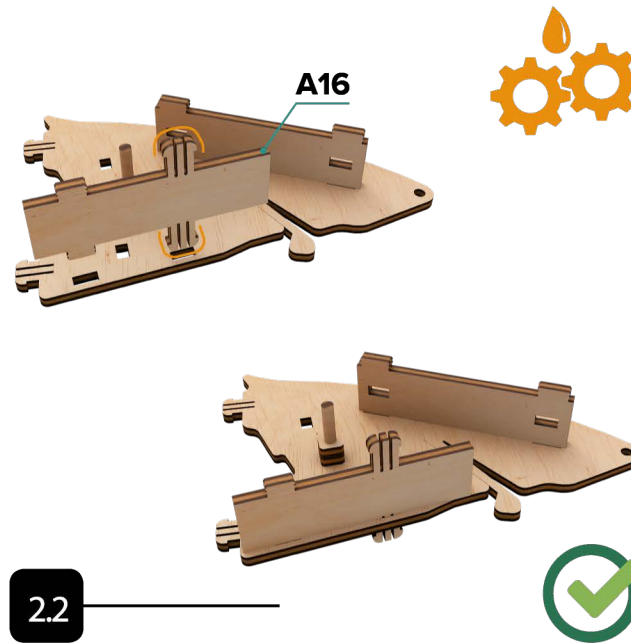
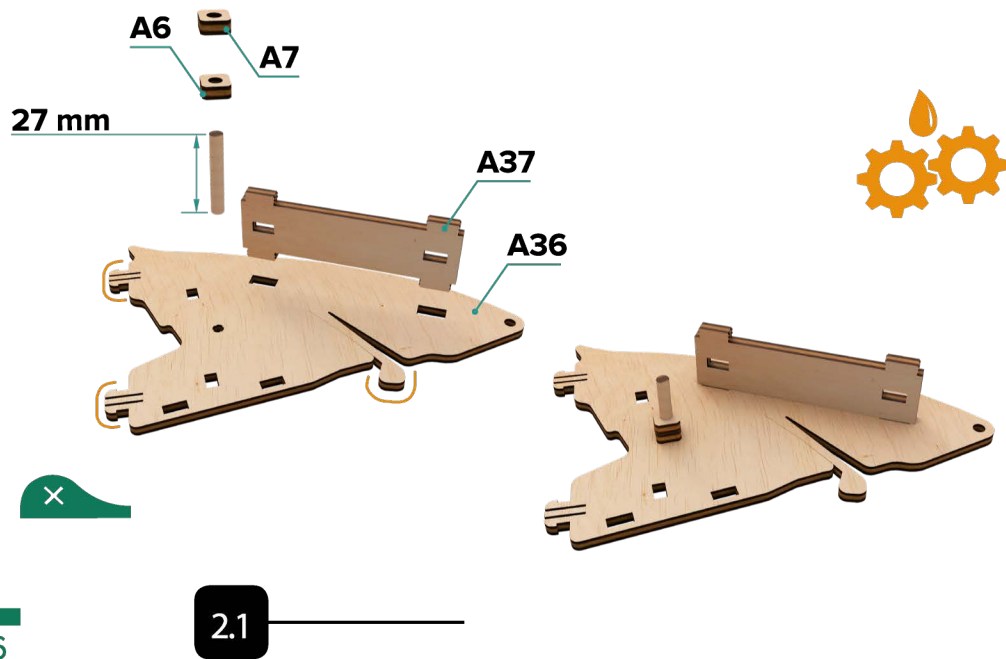
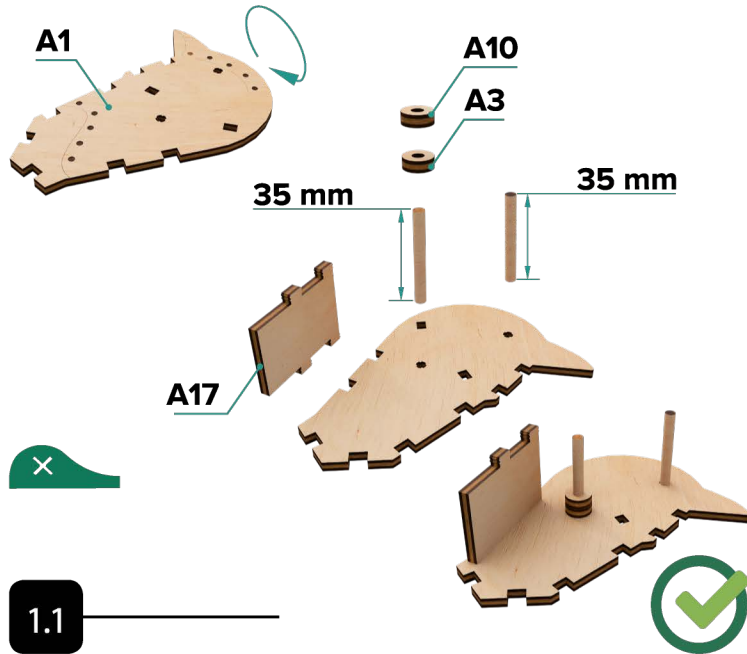

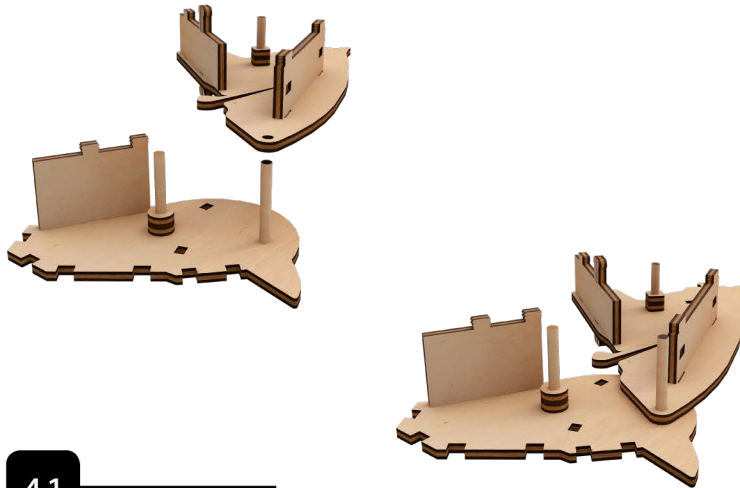

4.1

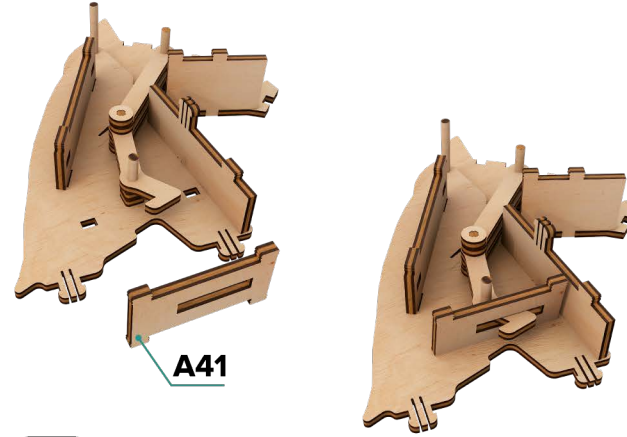

4.3

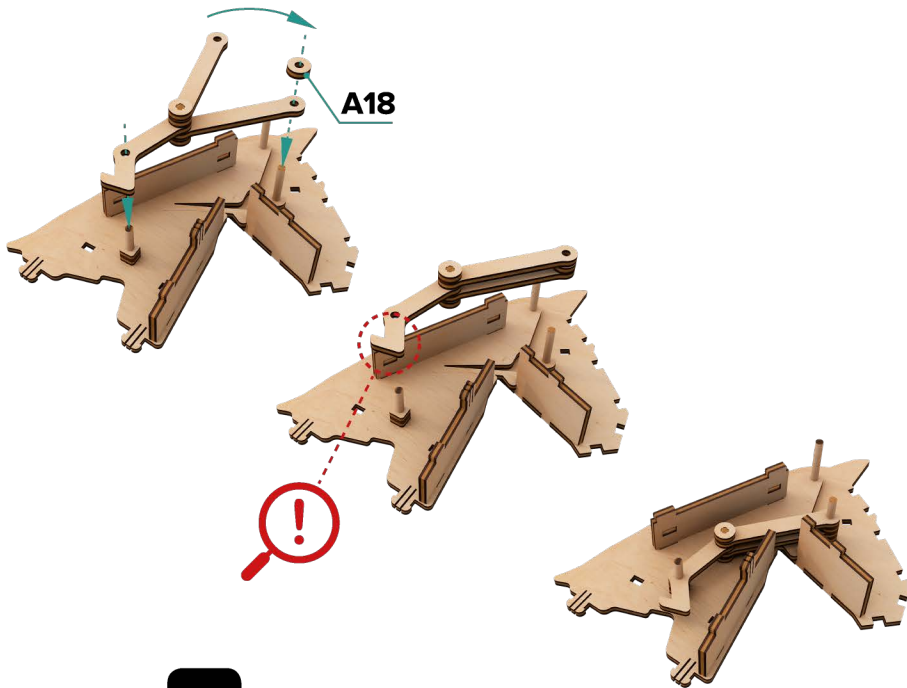

4.2

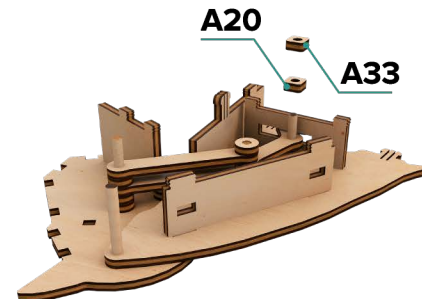

4.4

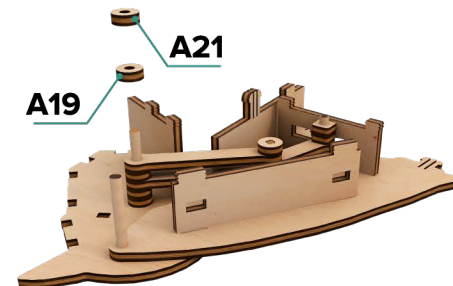

4.5

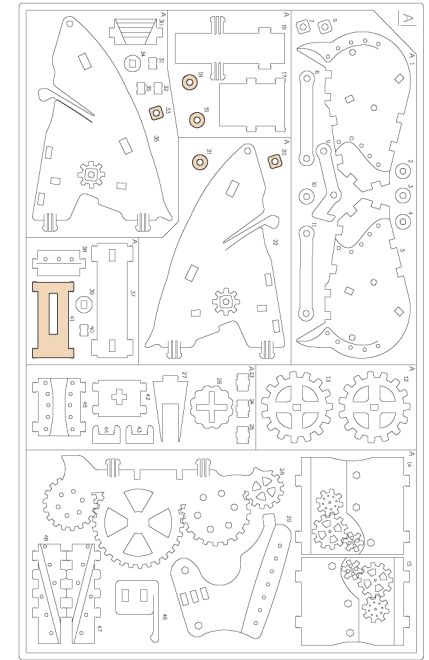



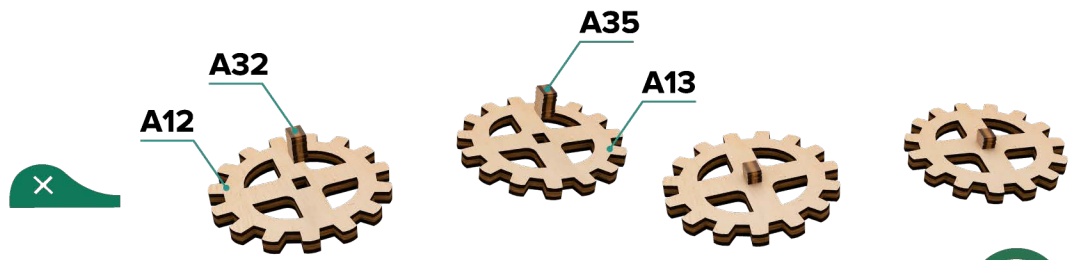
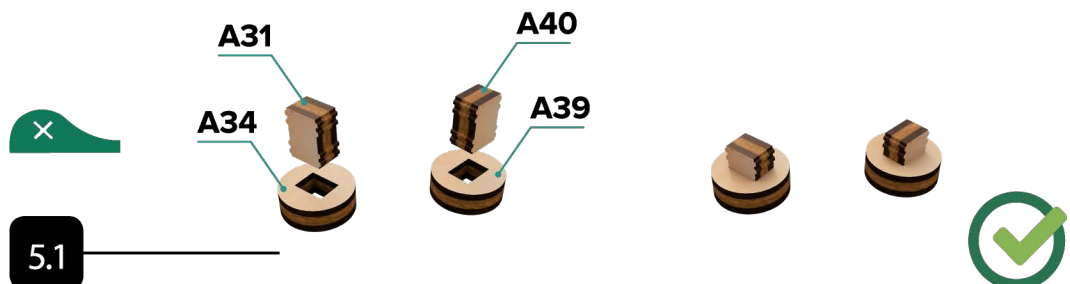
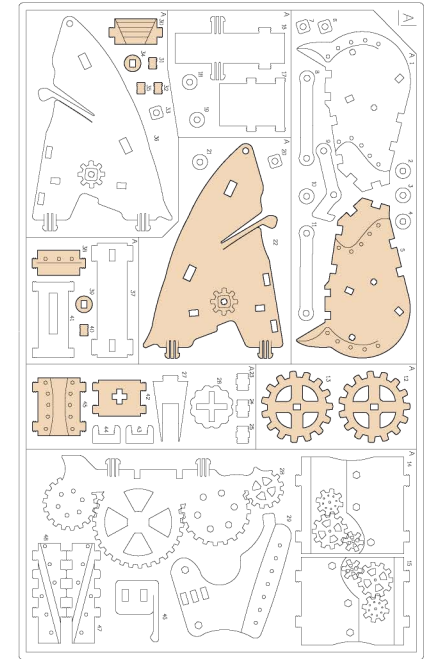
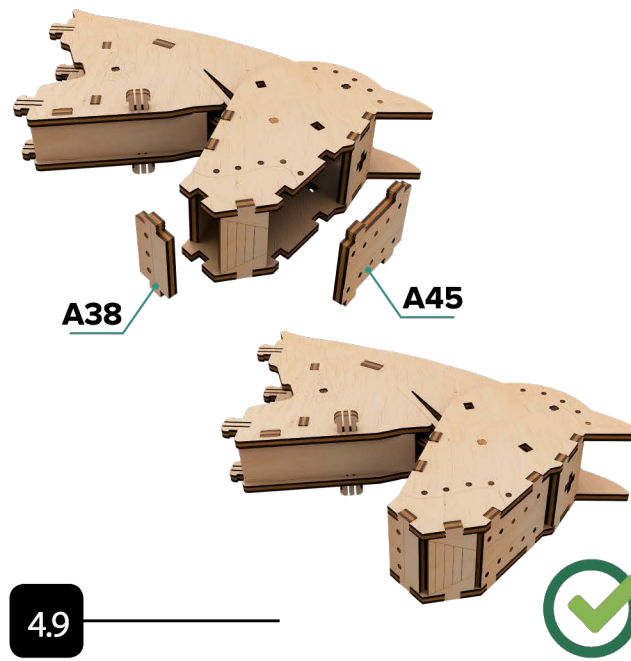
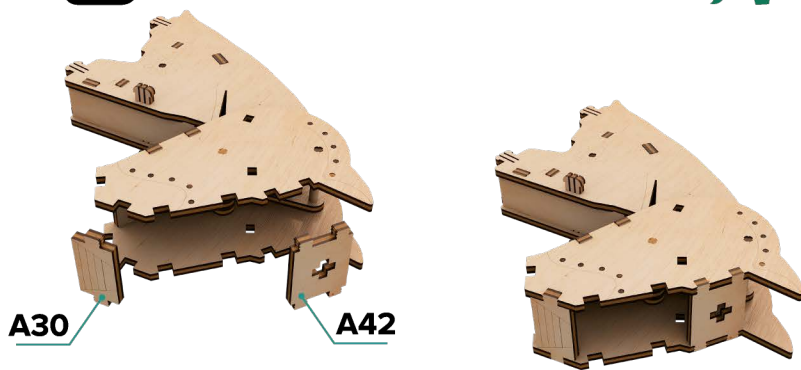
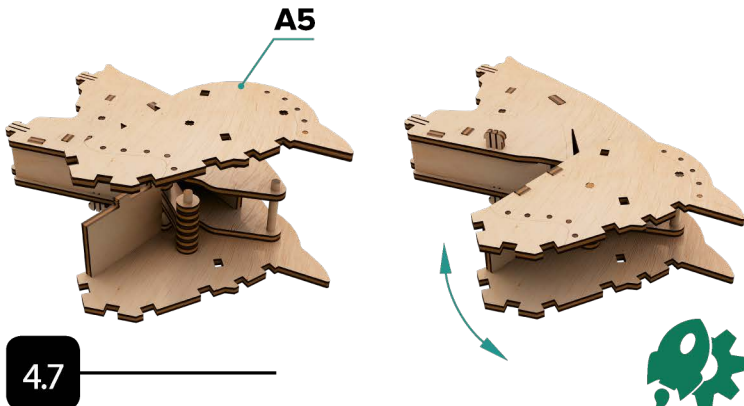
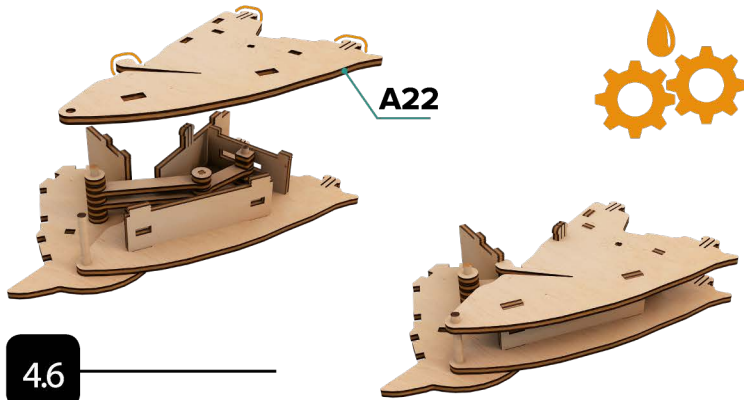



MR.  
PLAY  
WOOD

GIFT FOR  
GIFTED

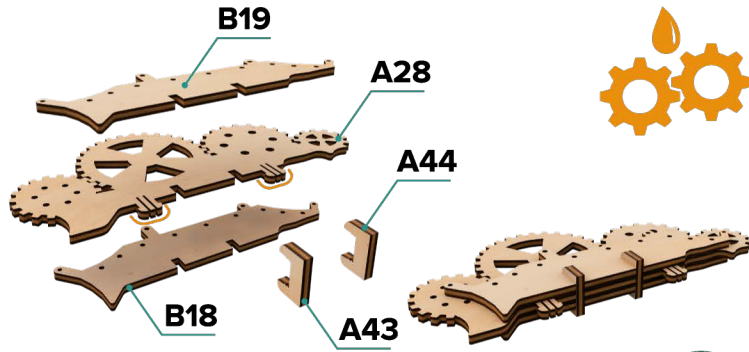

7.1

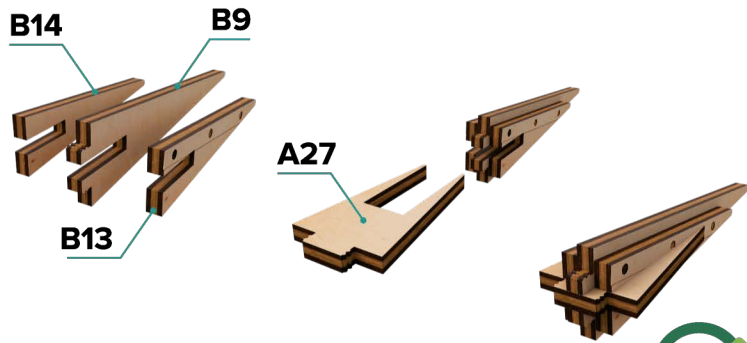

8.1

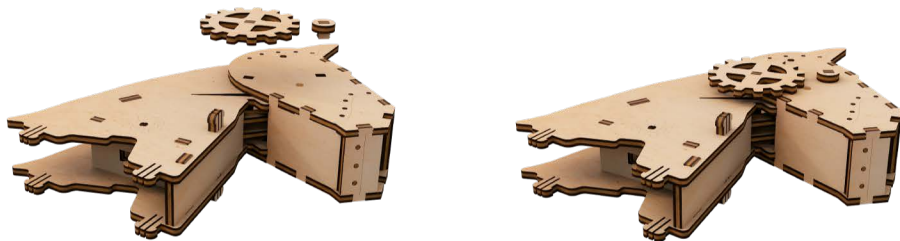

9.1

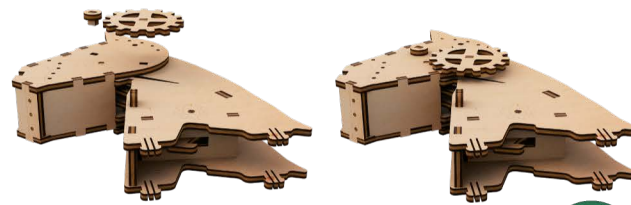

9.2



9.3

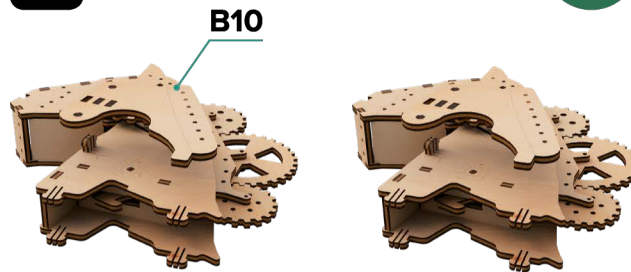

9.4



9.5

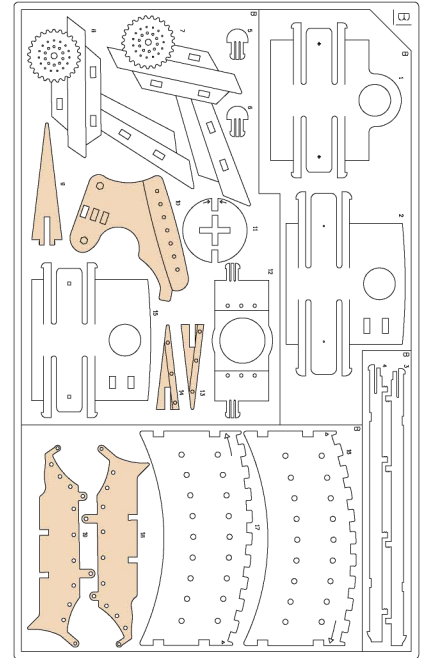
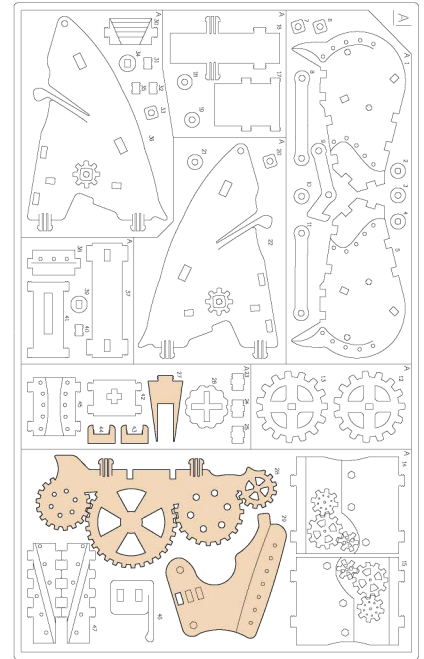

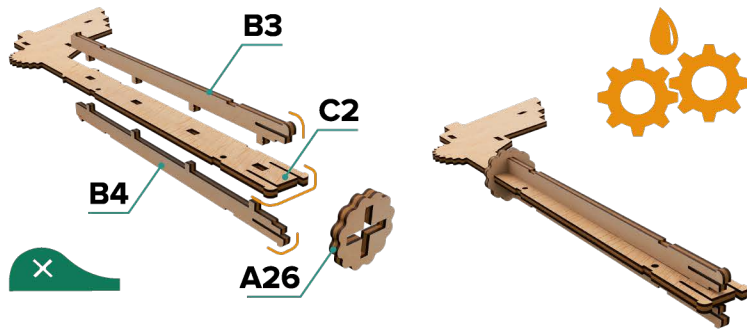

8.1

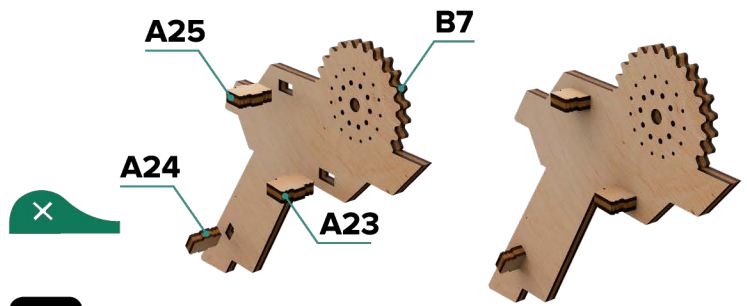

8.2



8.3

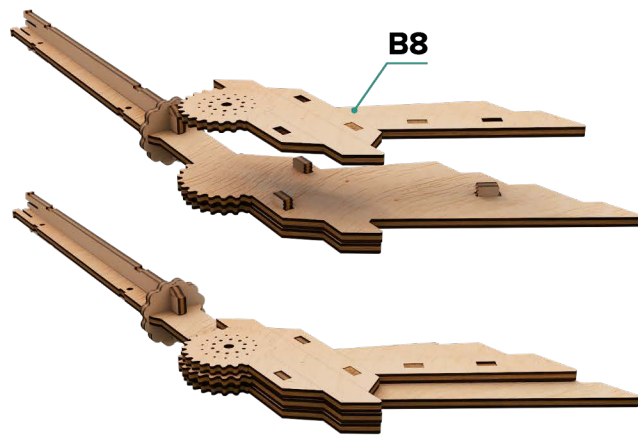

8.4

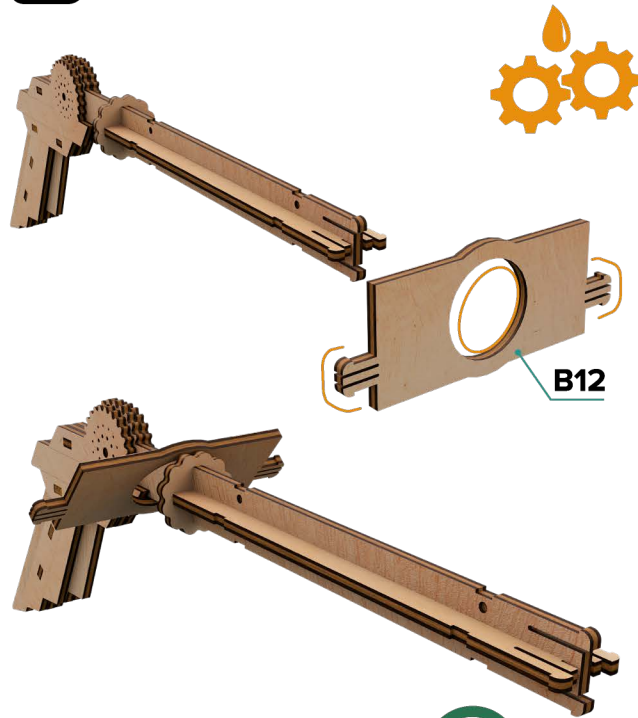

8.5

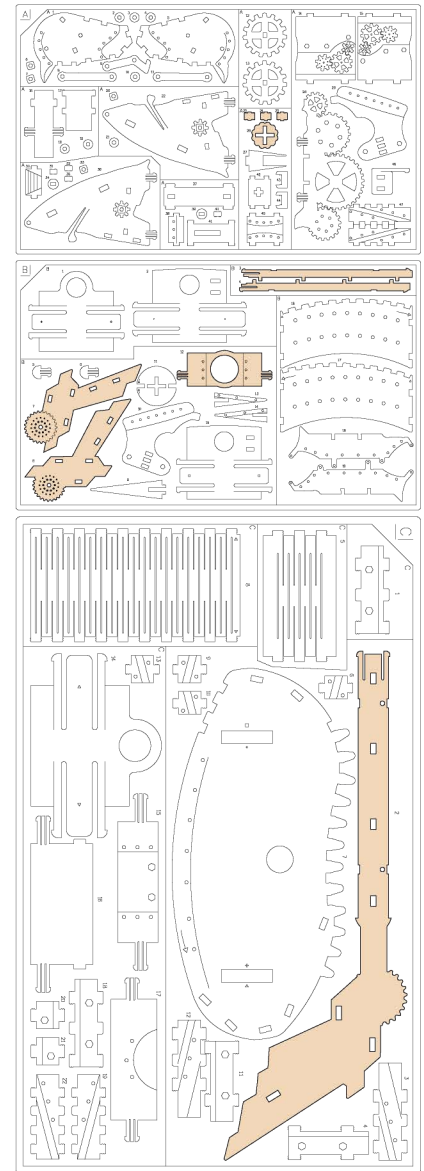



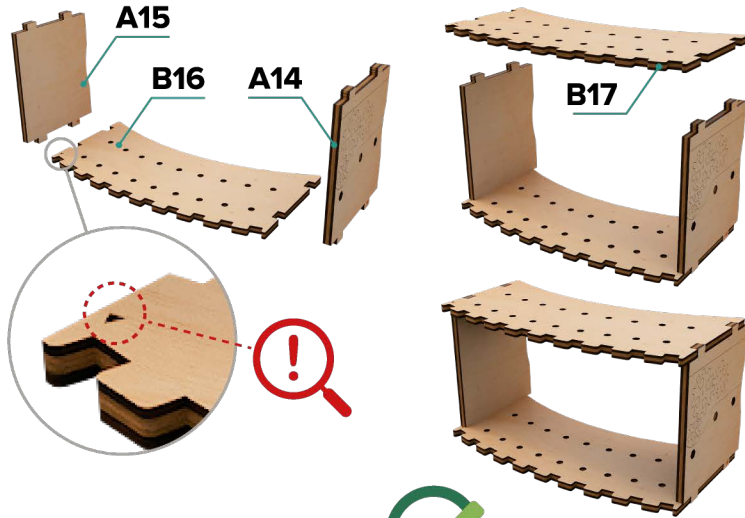

9.1

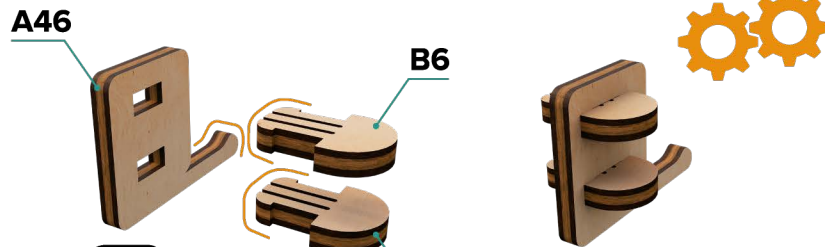

10.1

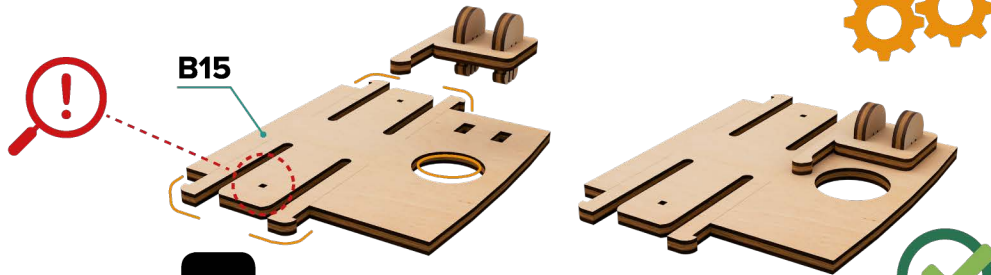

10.2

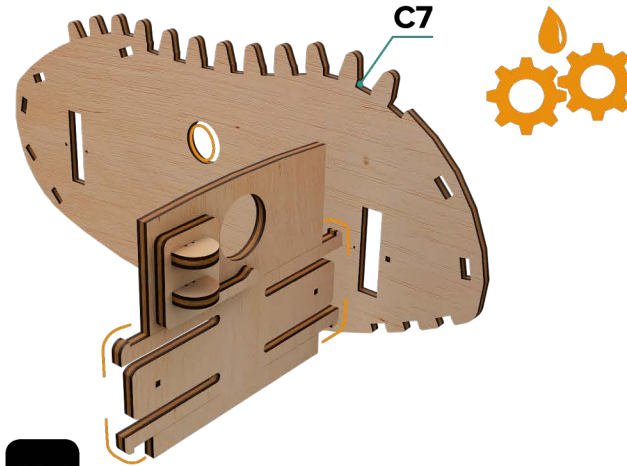

11.1

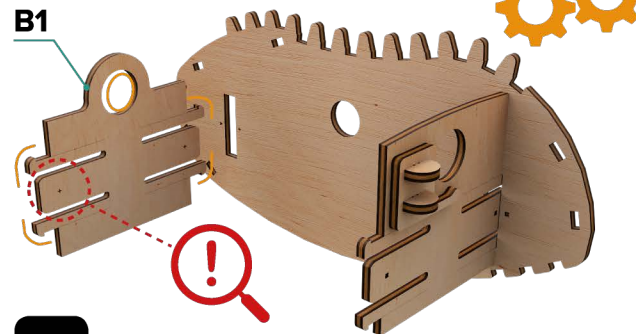

11.2

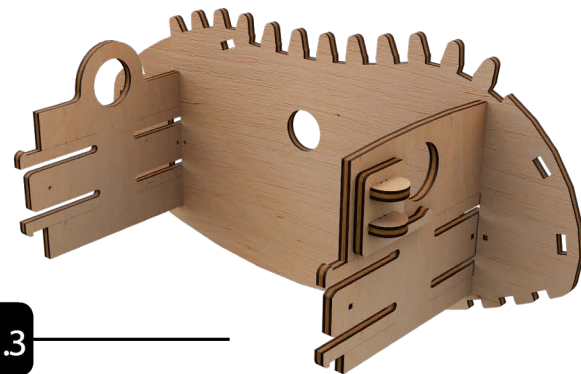

11.3

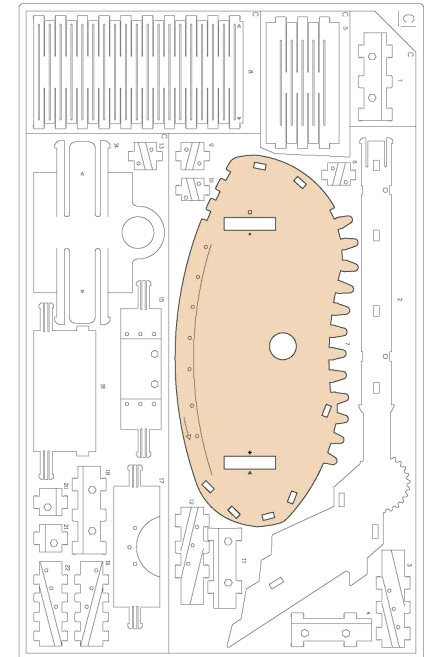
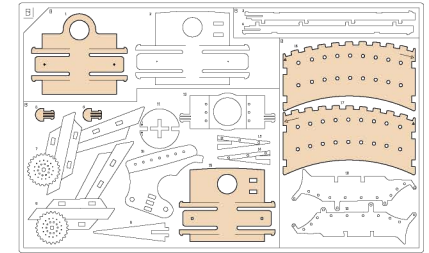
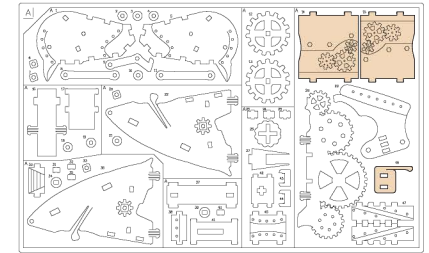

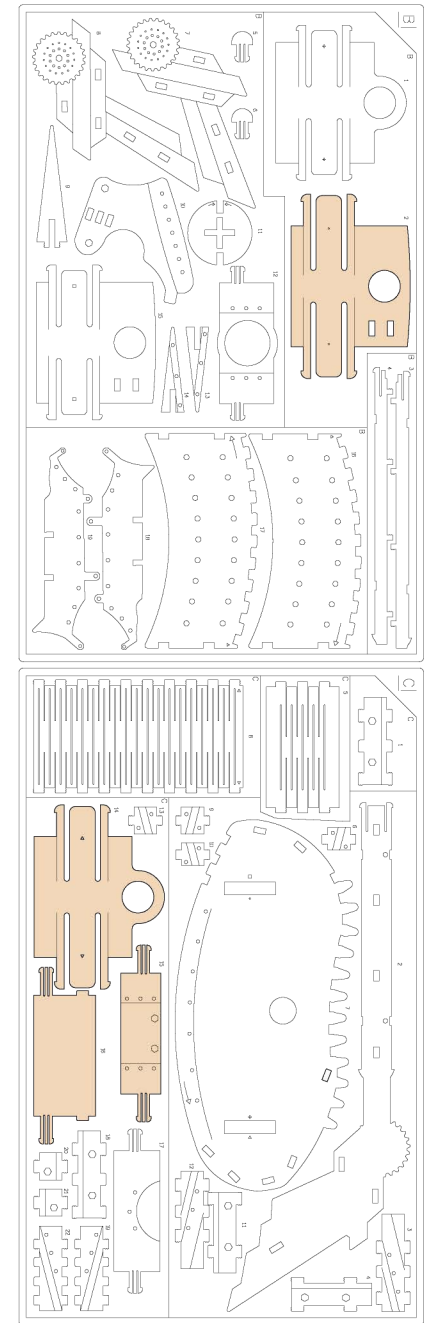
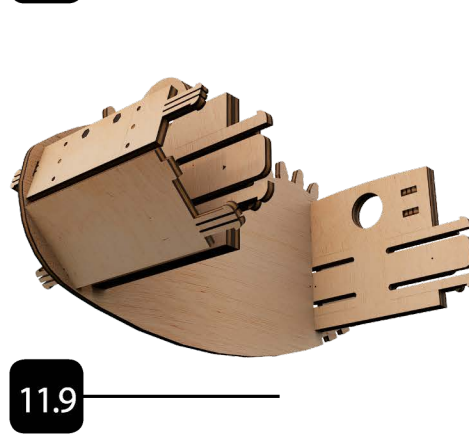
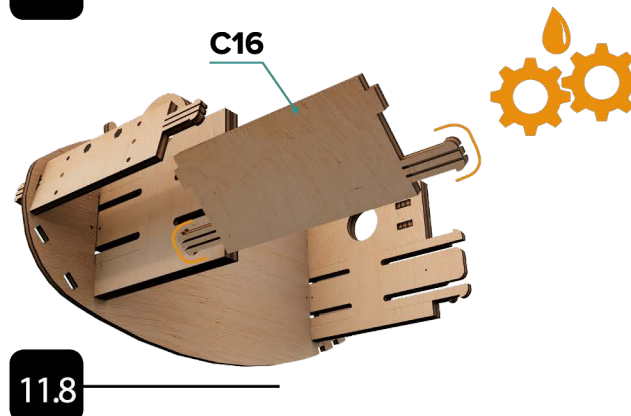
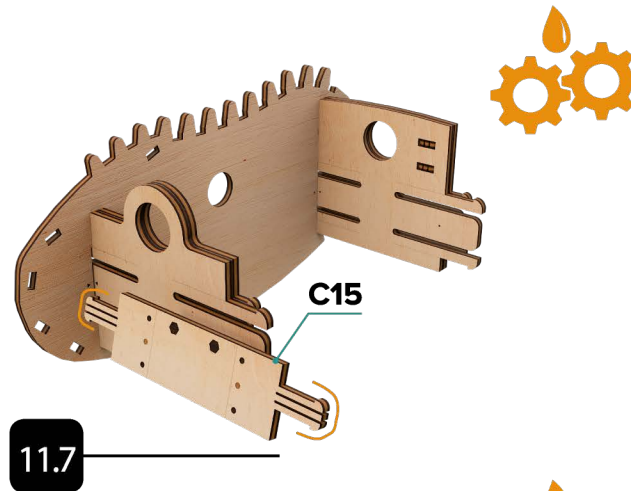
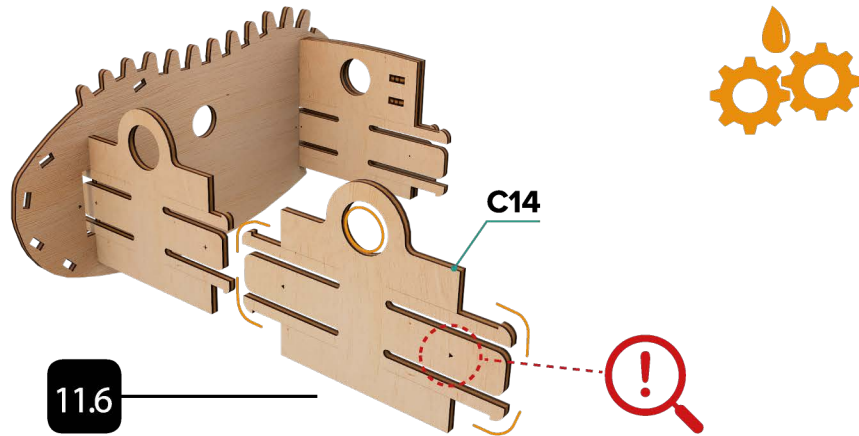
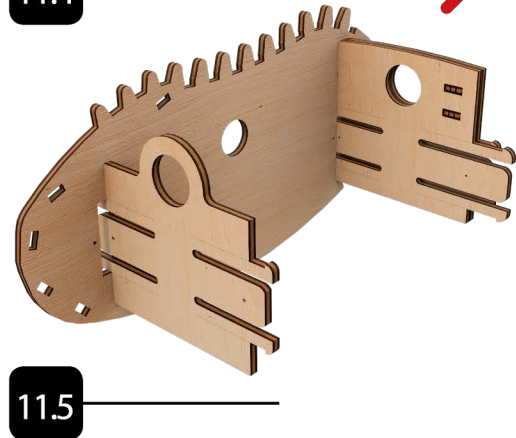
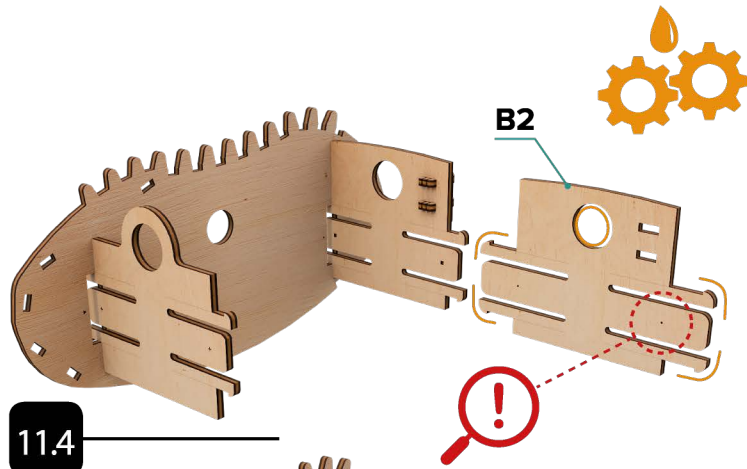



MR.  
PLAY  
WOOD

GIFT FOR  
GIFTED

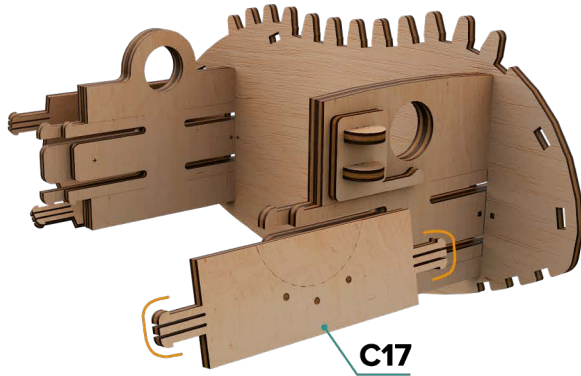

11.10

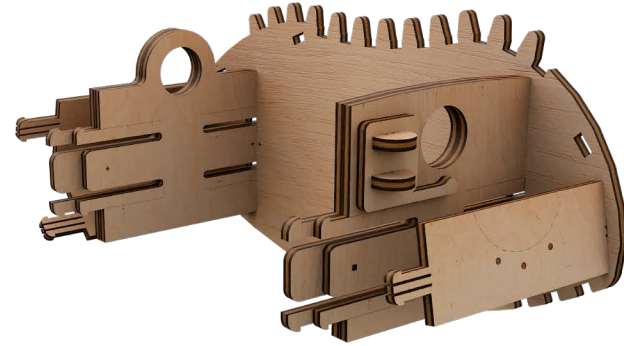

11.11

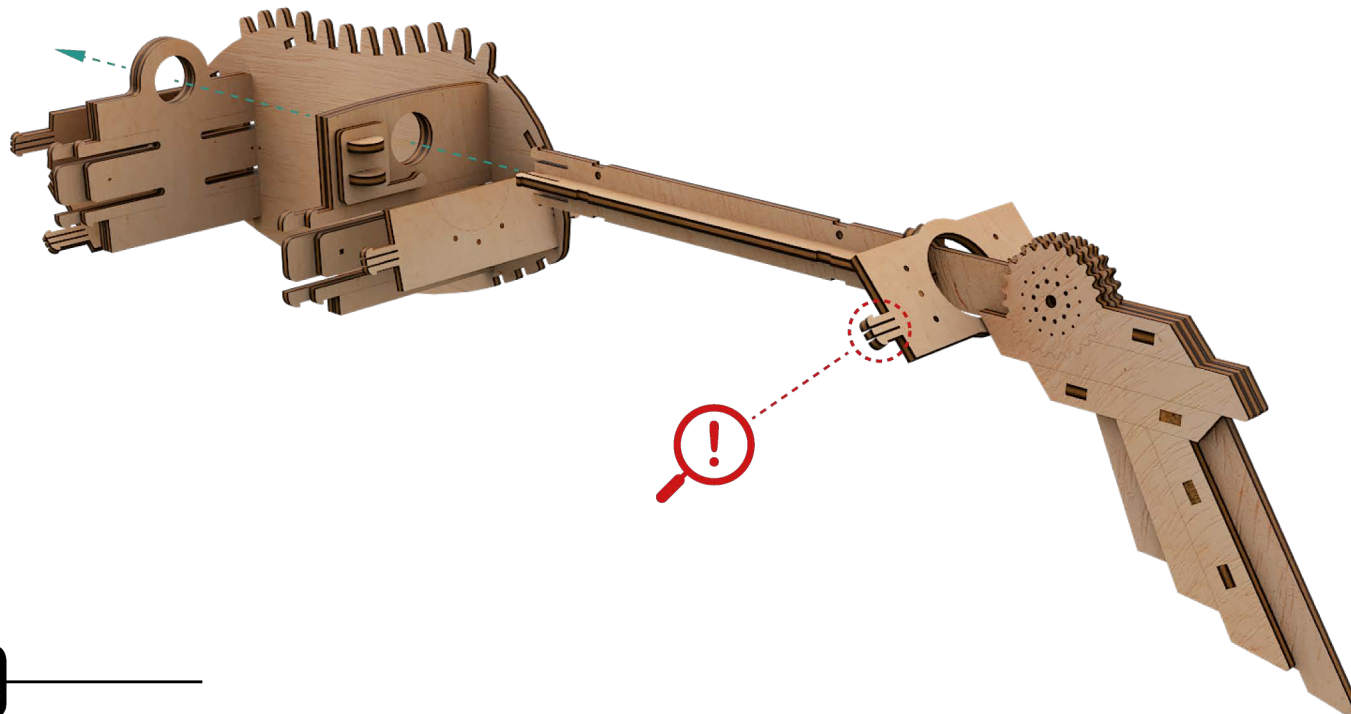
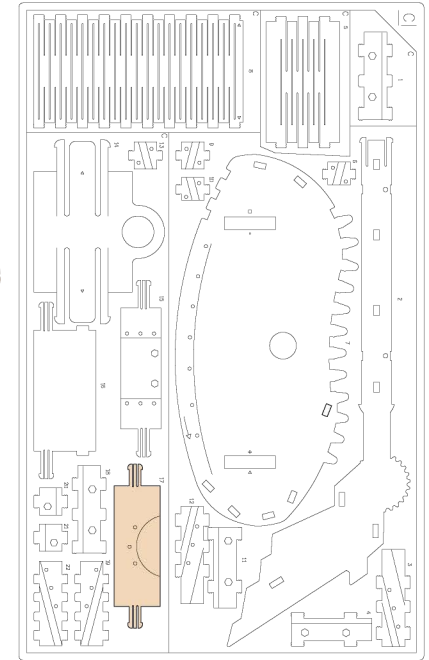

11.12





MR.  
PLAY  
WOOD

GIFT FOR  
GIFTED

11.13

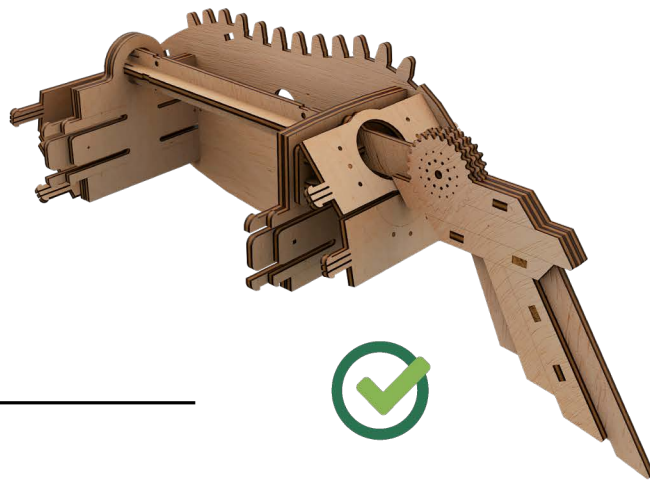

B11

11.14

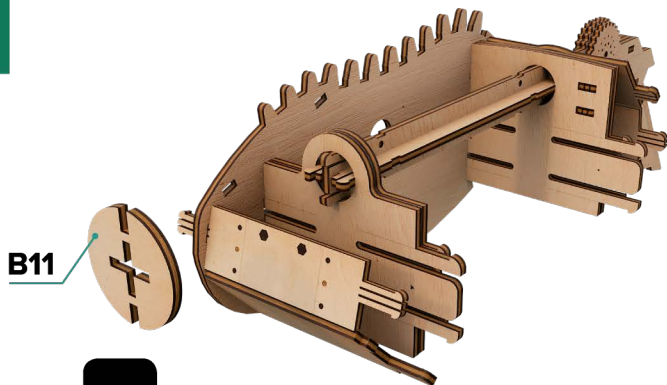

11.15

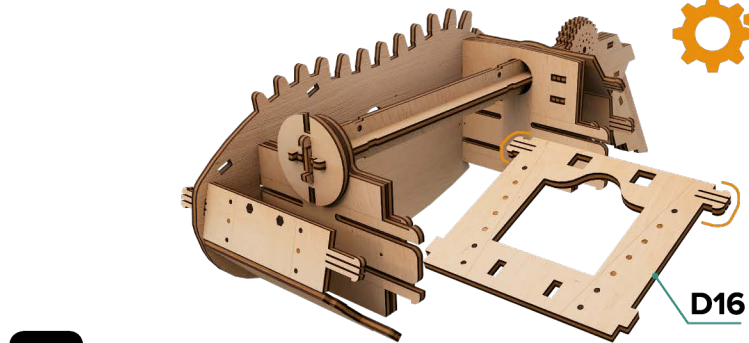

D16

11.16

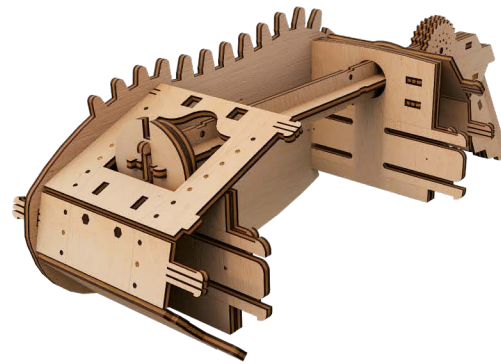

D12

11.17

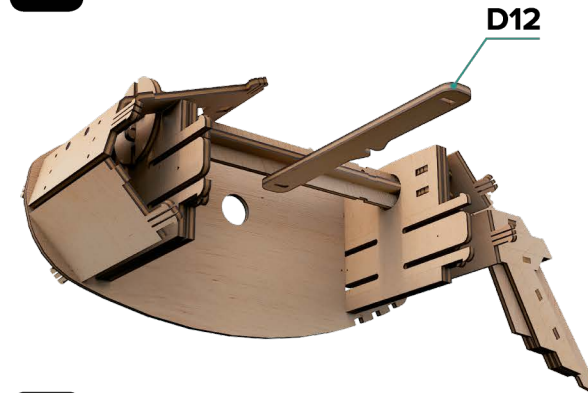

D13

11.18

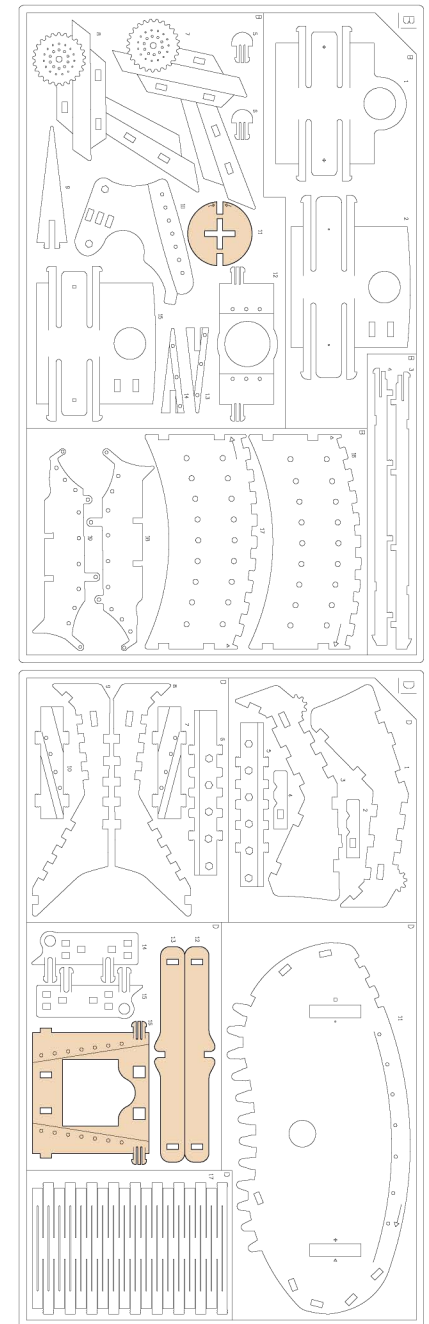
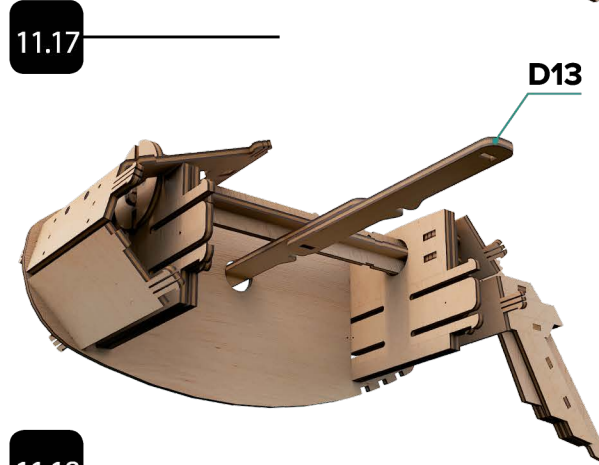



**MR.  
PLAY  
WOOD**  
GIFT FOR  
GIFTED

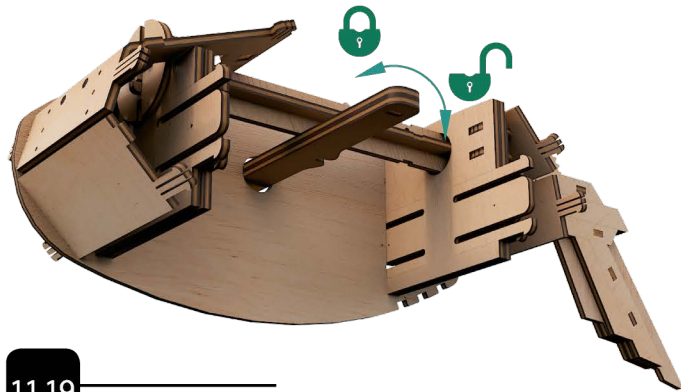

11.19

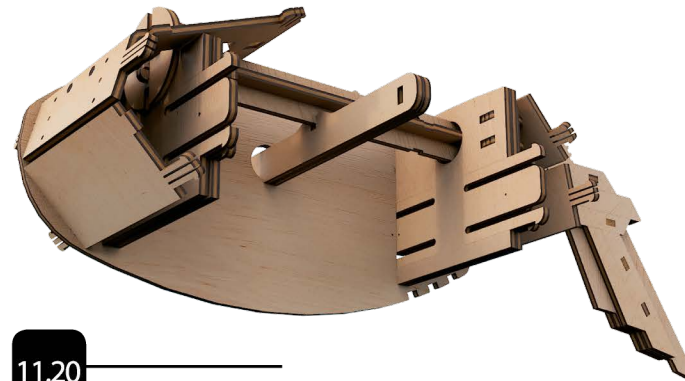

11.20

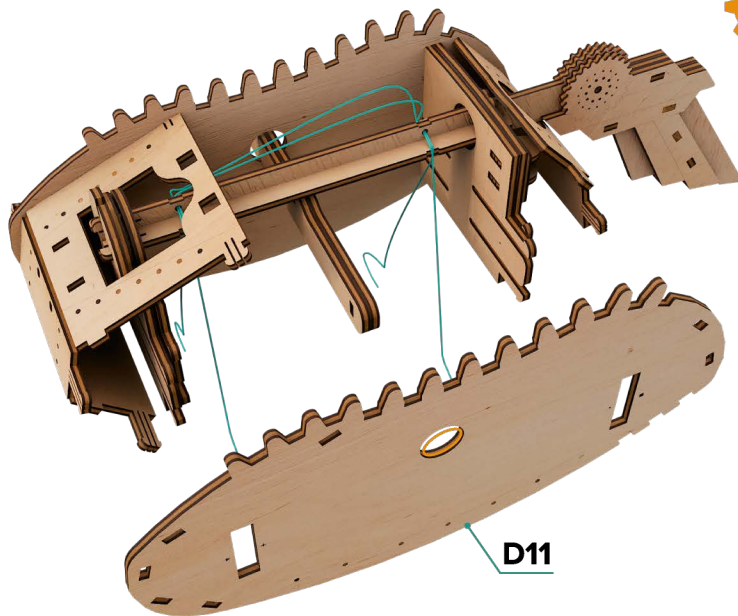
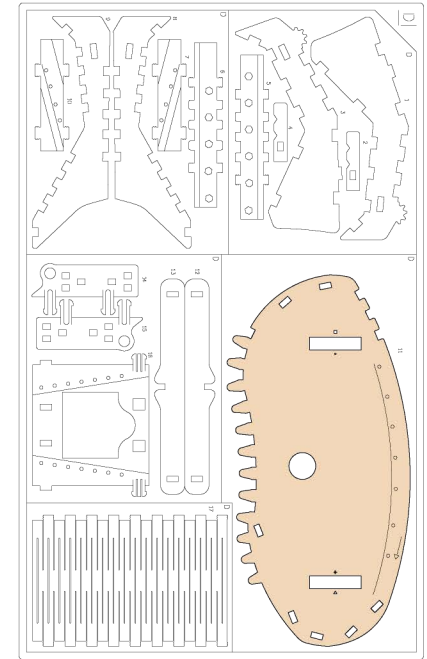

D11

11.21

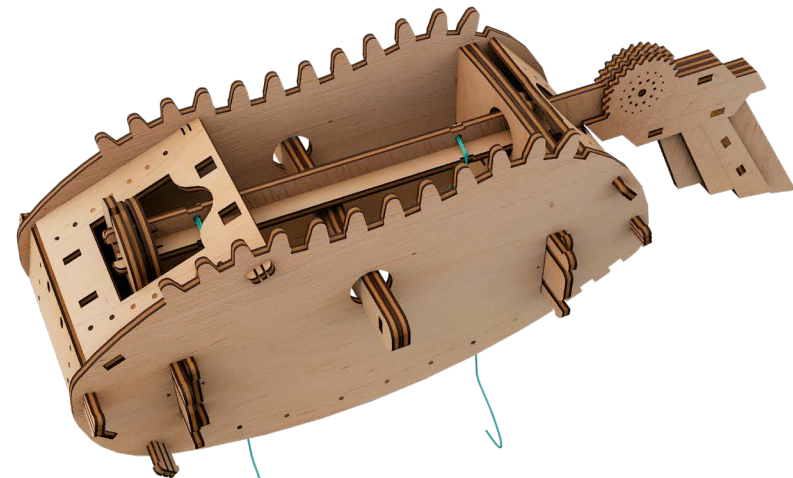

11.22





MR.  
PLAY  
WOOD  
GIFT FOR  
GIFTED

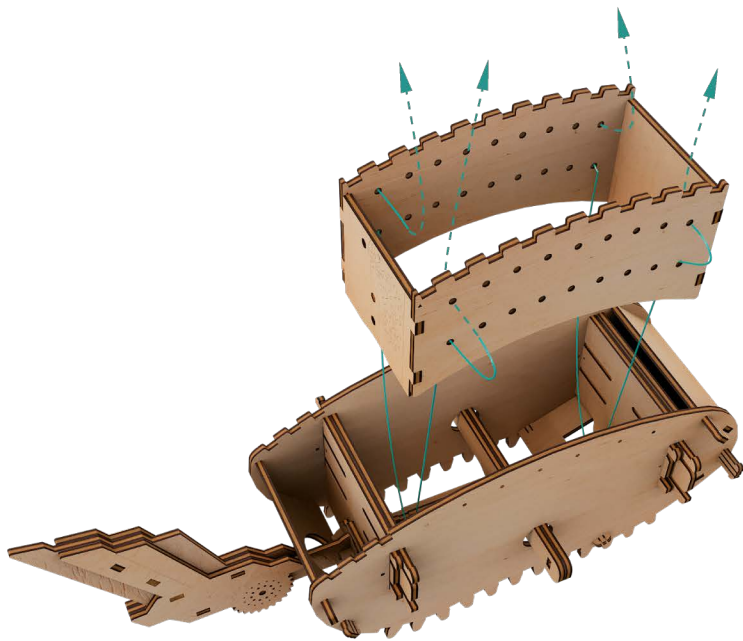

11.23

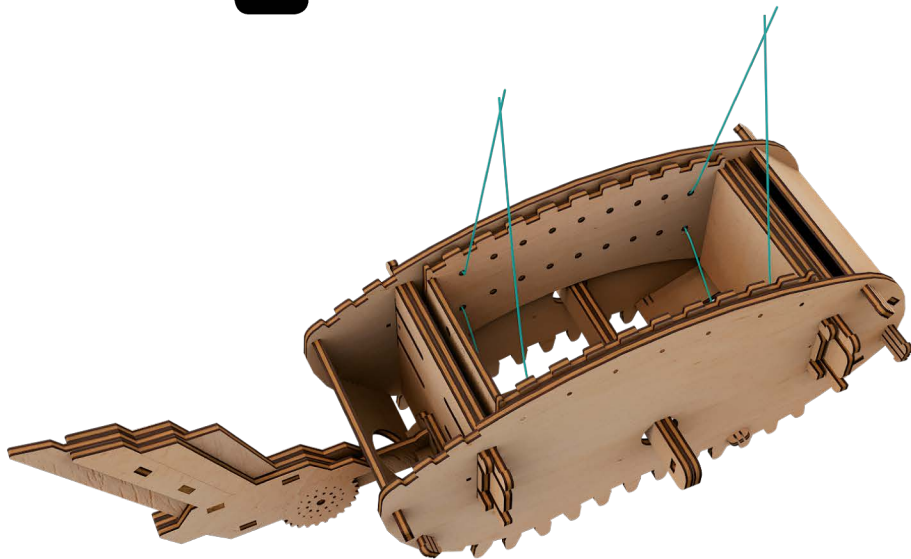

11.24

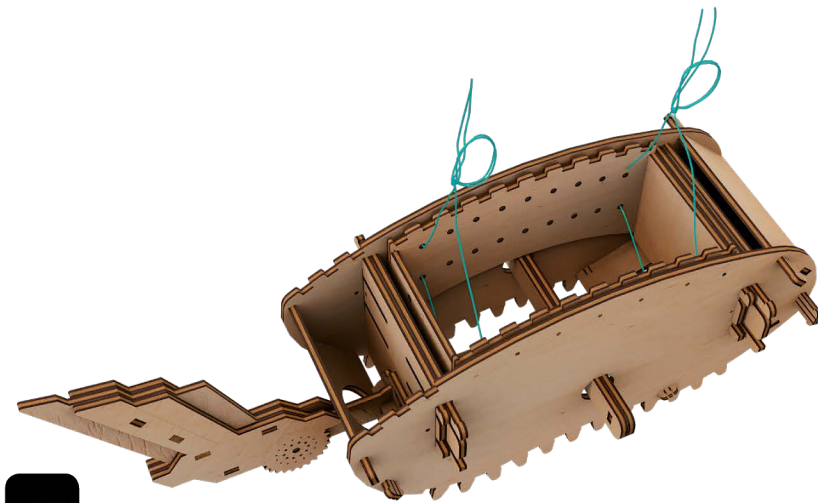

11.25

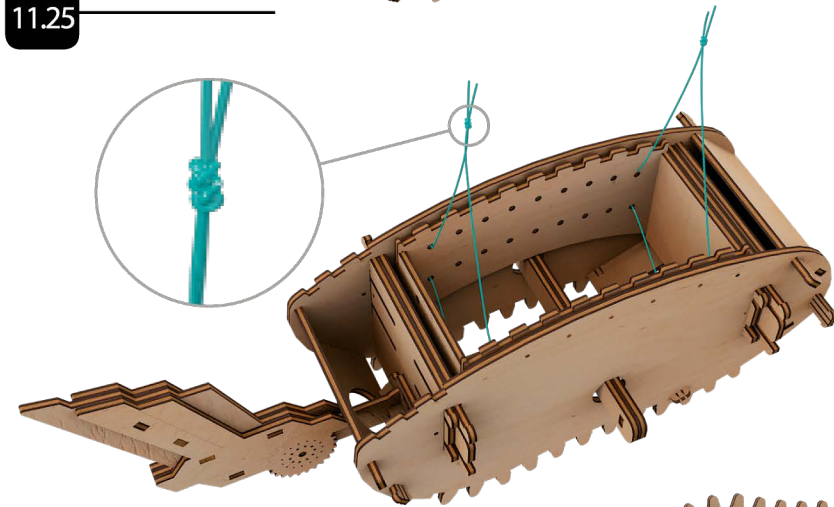

11.26

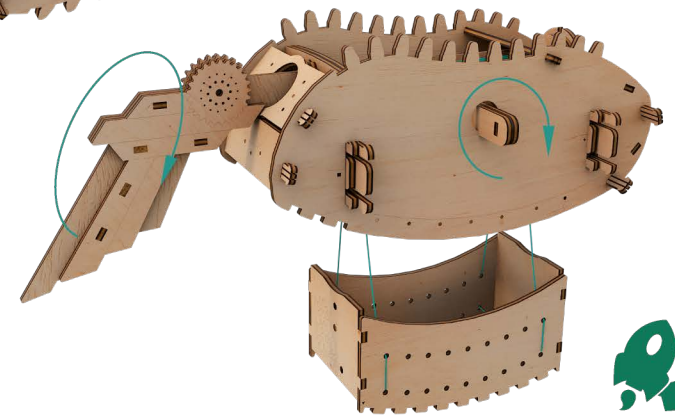





MR.  
PLAY  
WOOD

GIFT FOR  
GIFTED



11.27

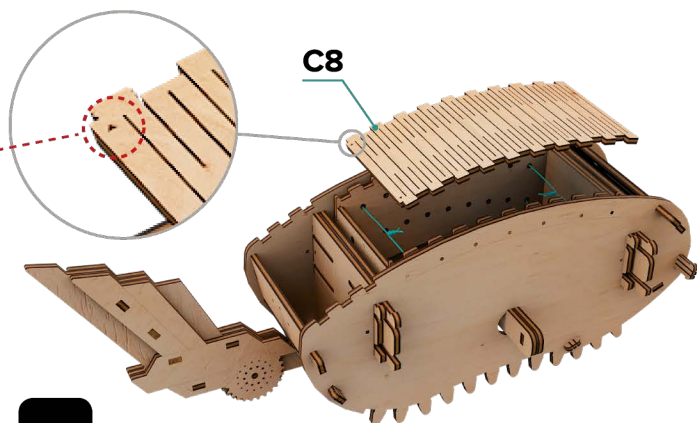

C8

11.28



11.29

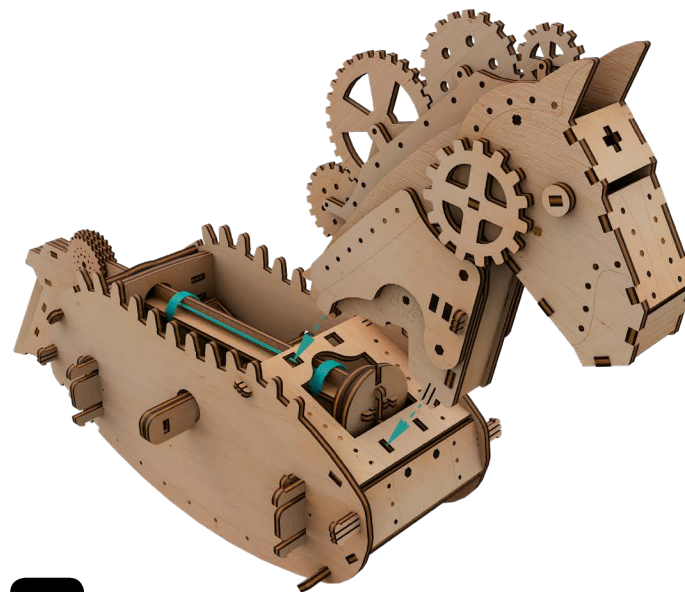

11.30

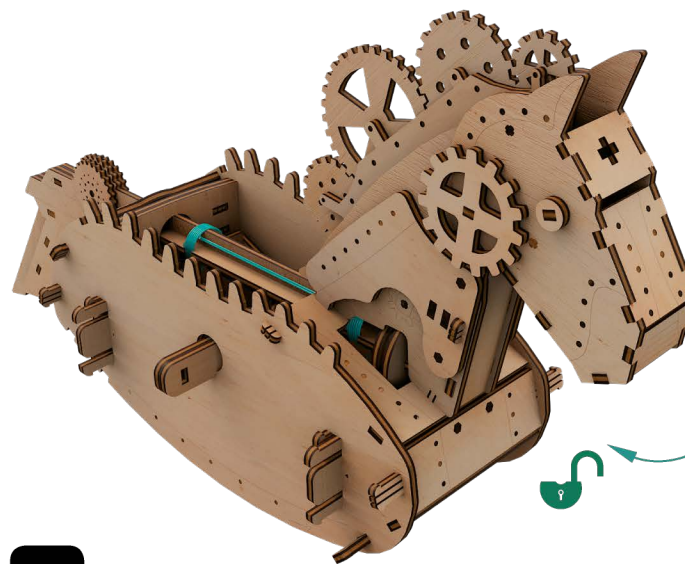
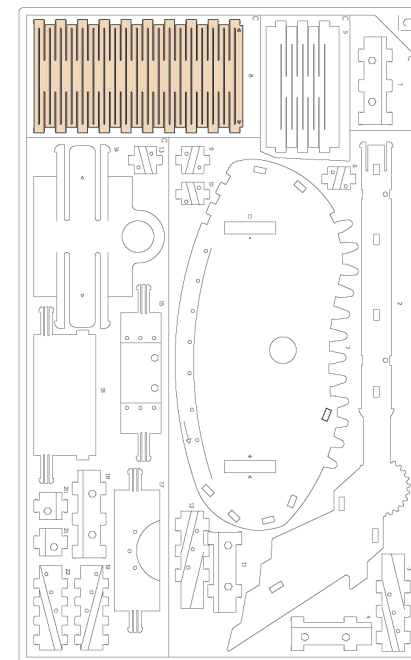

11.31





MR.  
PLAY  
WOOD

GIFT FOR  
GIFTED

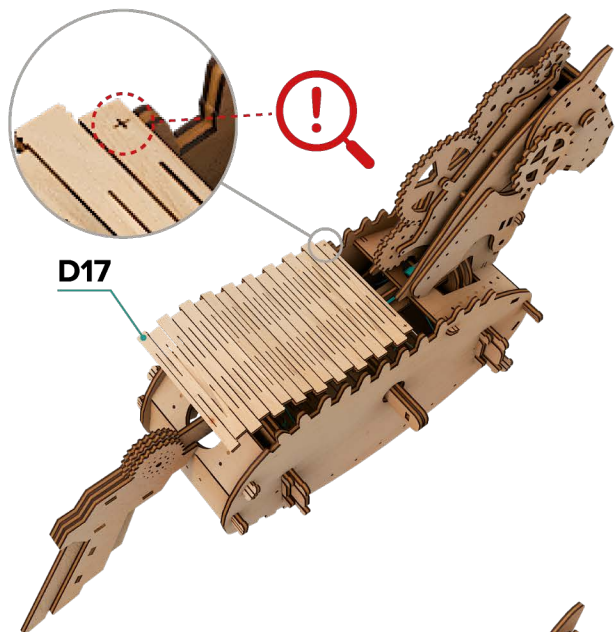

D17

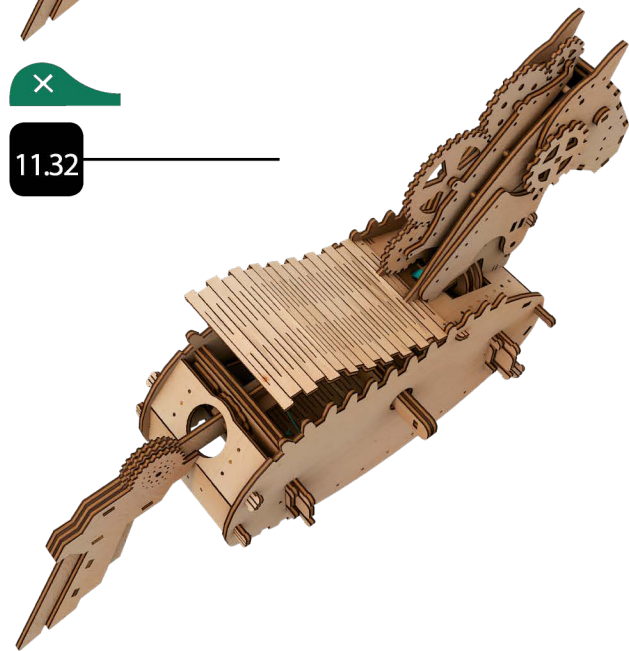

X

11.32

11.33

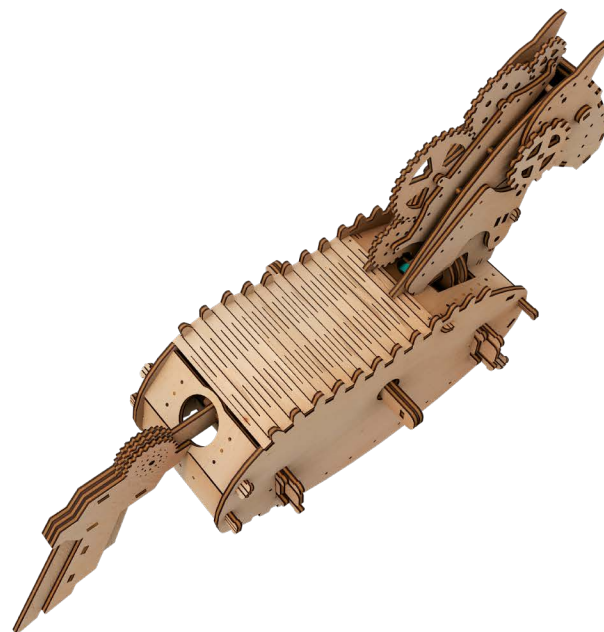

11.34

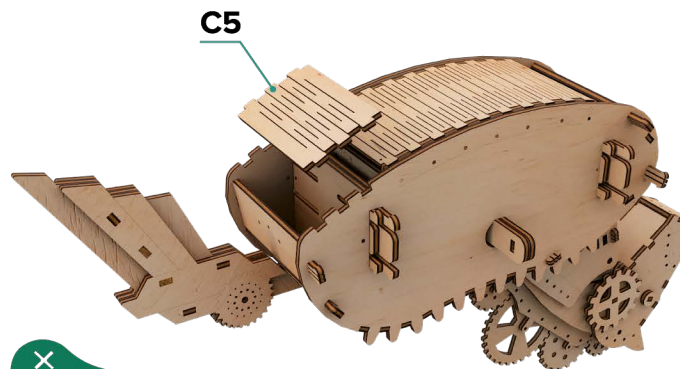

C5

X

11.35

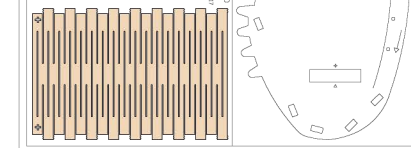
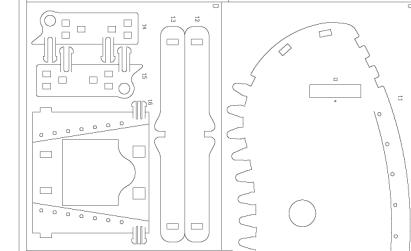
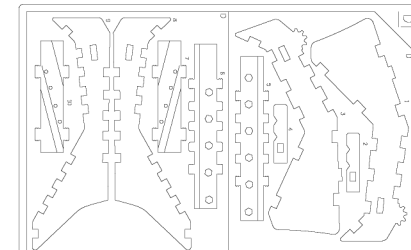
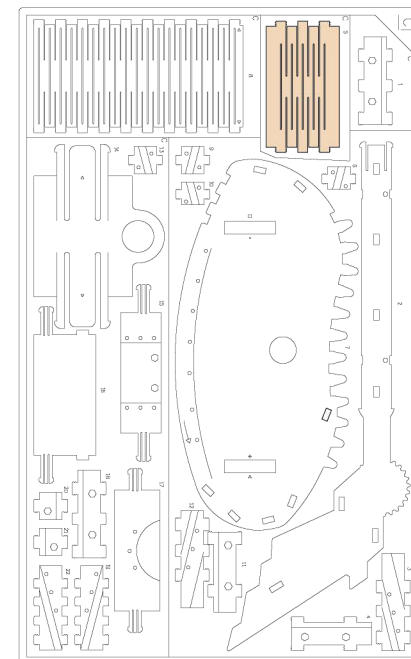



MR.  
PLAY  
WOOD

GIFT FOR  
GIFTED



11.36

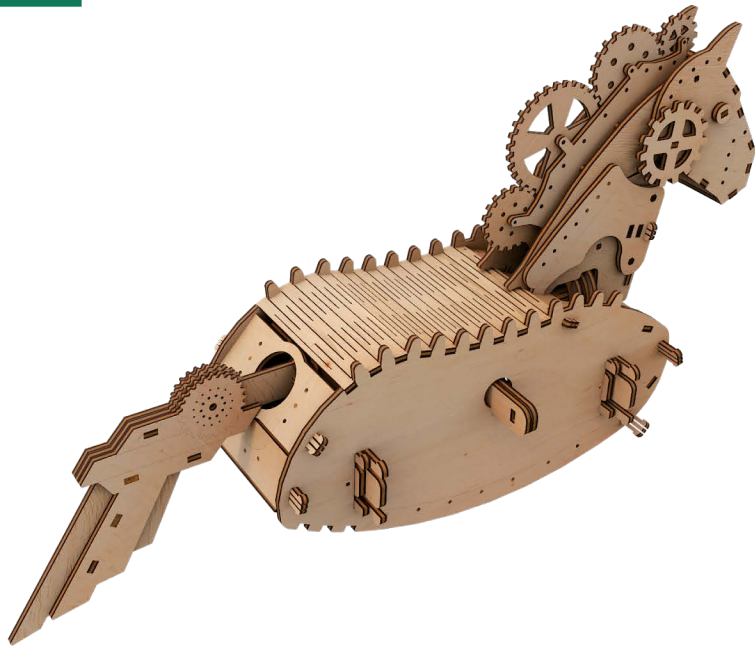

11.37

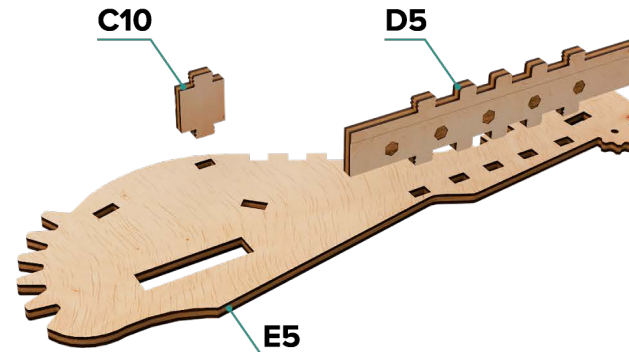

12.1

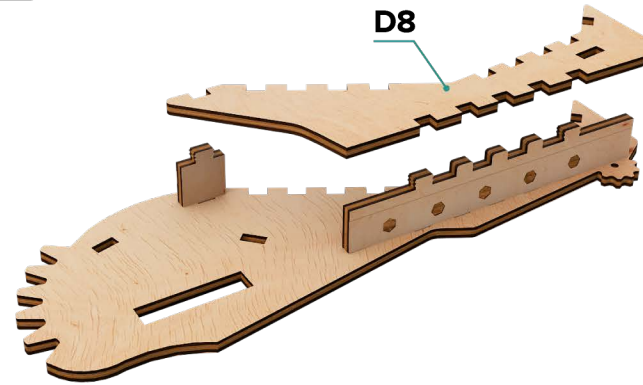

12.2

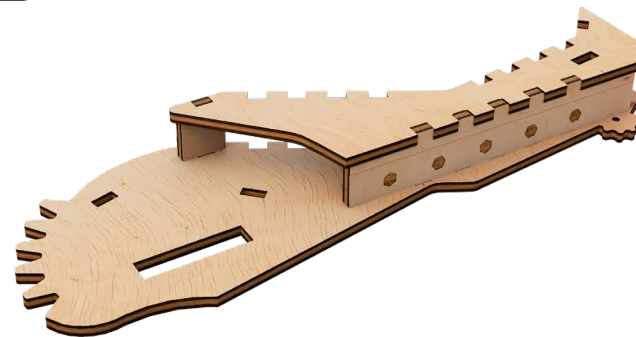

12.3

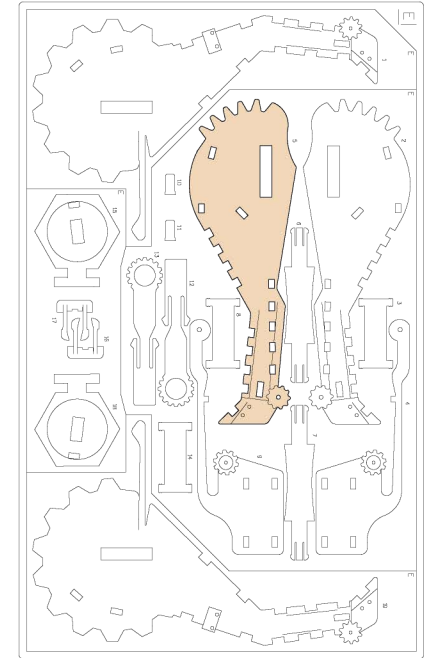
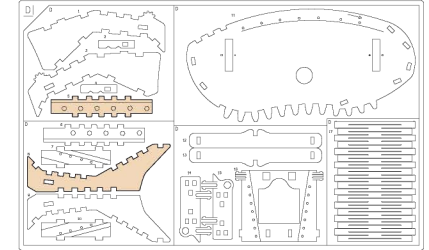
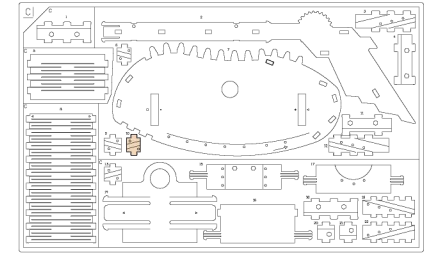



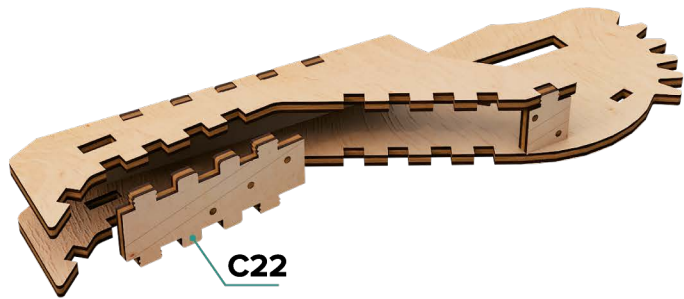

12.4

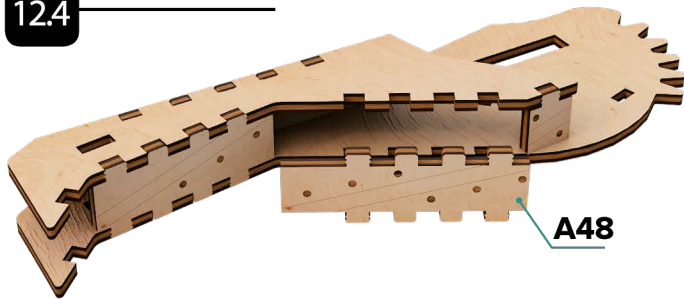

12.5



12.6

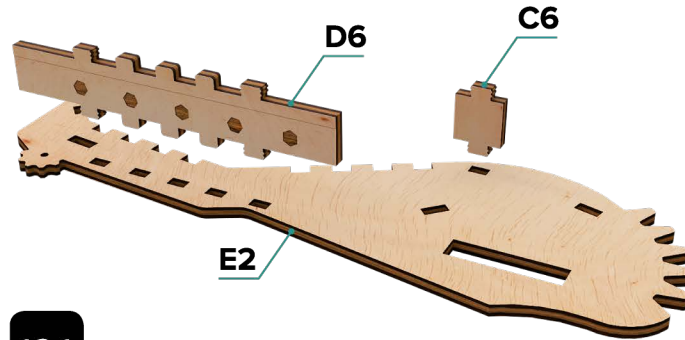

13.1

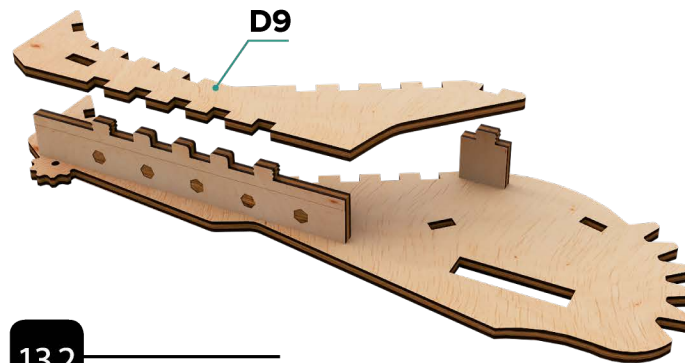

13.2

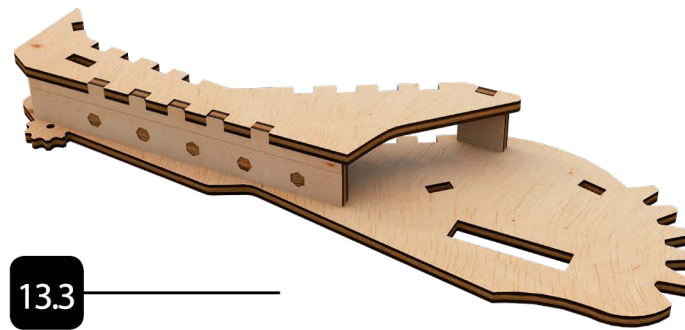

13.3

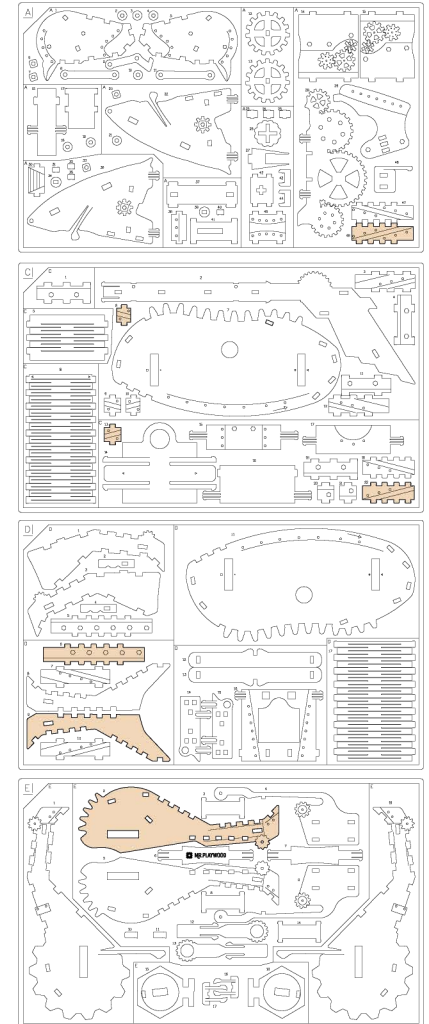

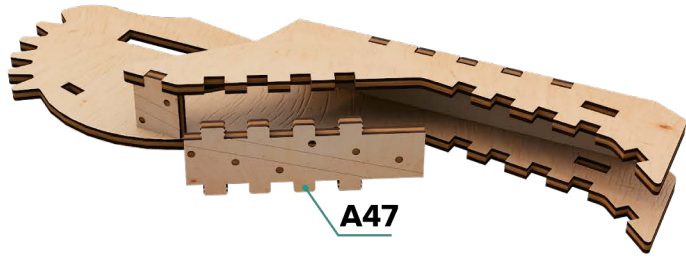

13.4

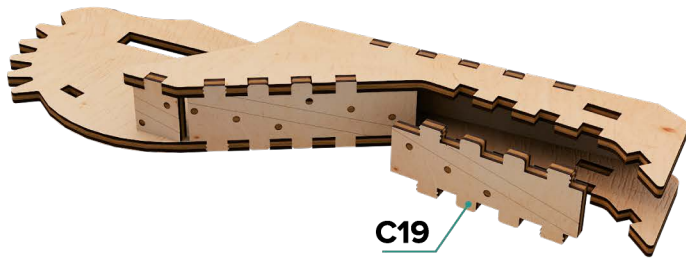

13.5

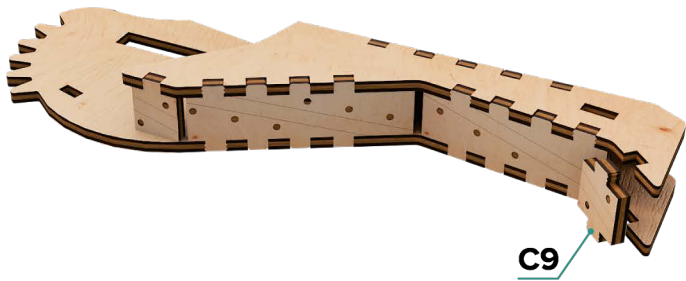

13.6



13.7

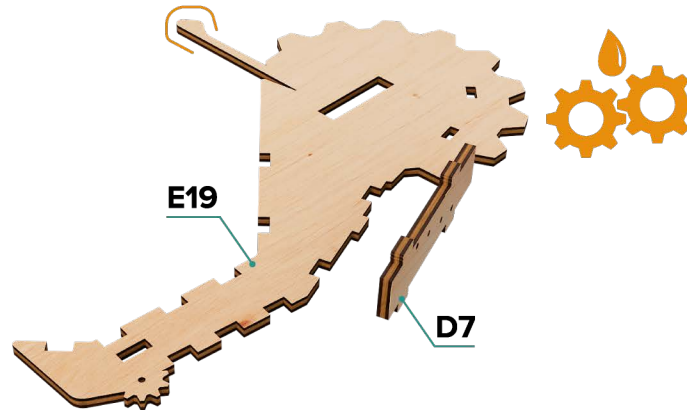

14.1

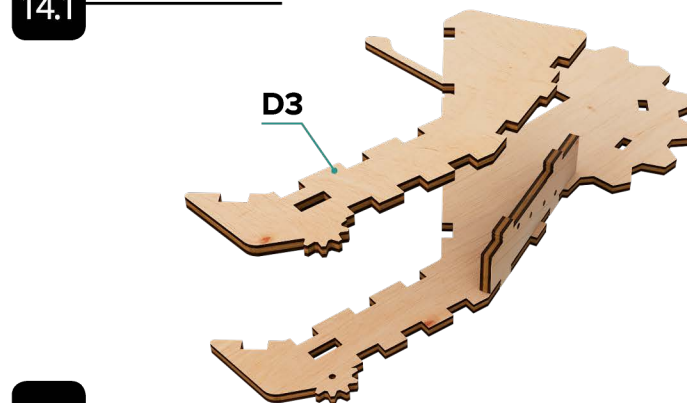

14.2

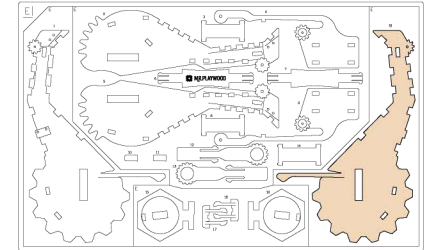
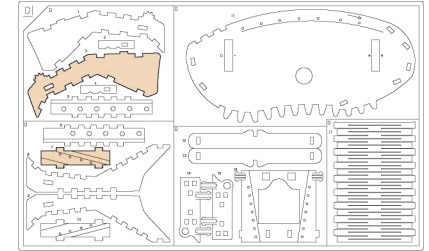
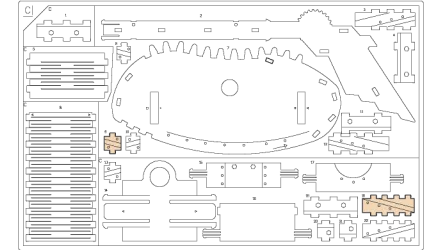
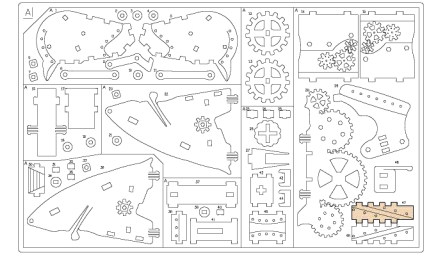



143



144

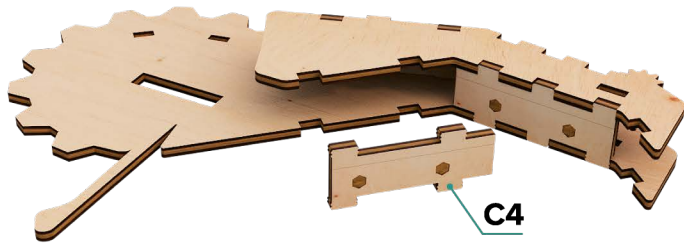

145



146



147



148

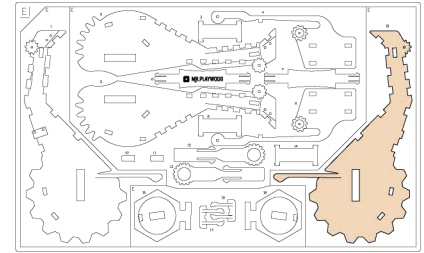
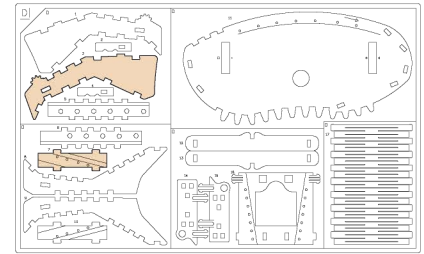
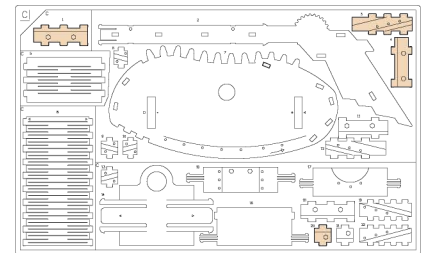
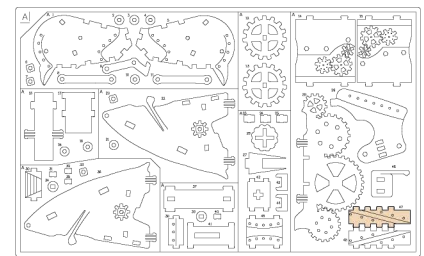



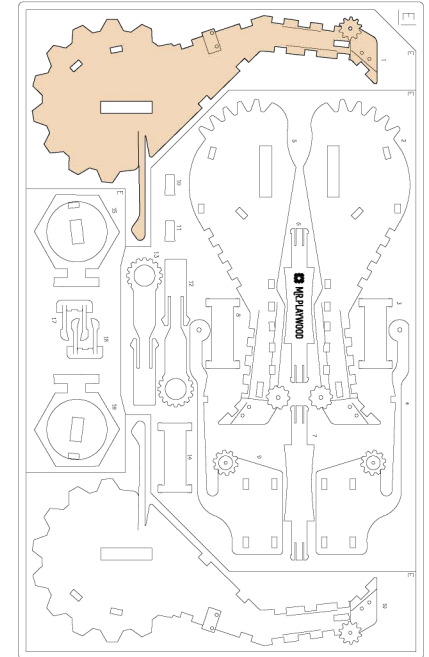
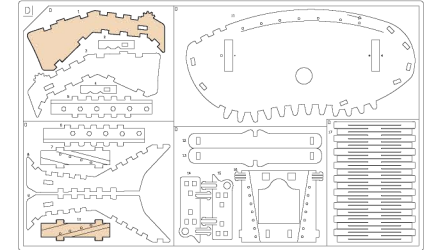
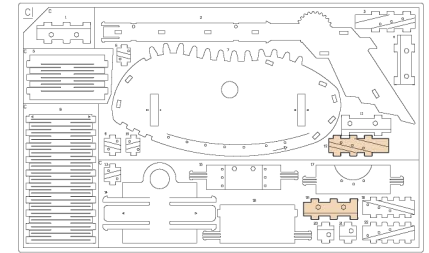
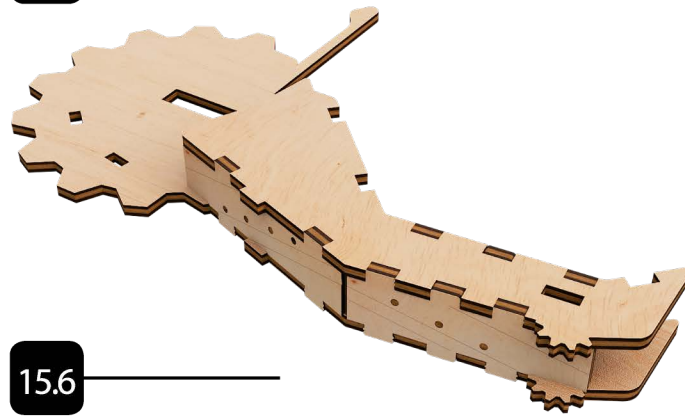
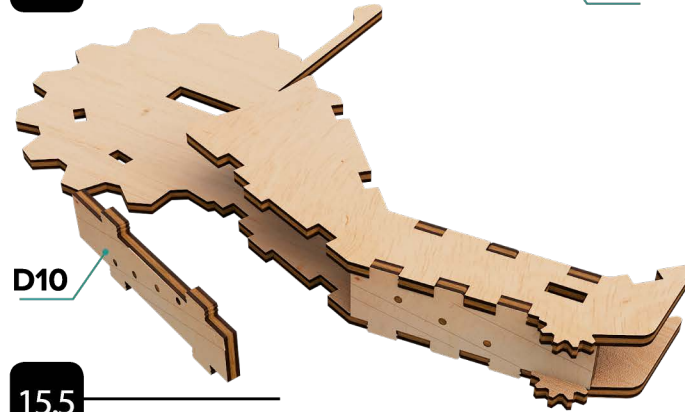
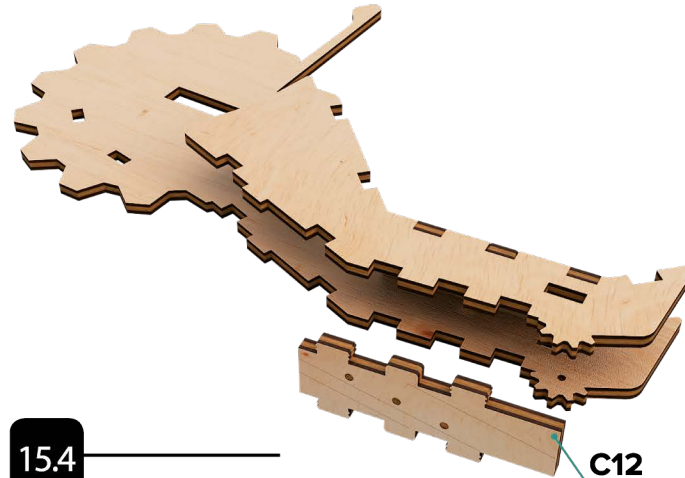
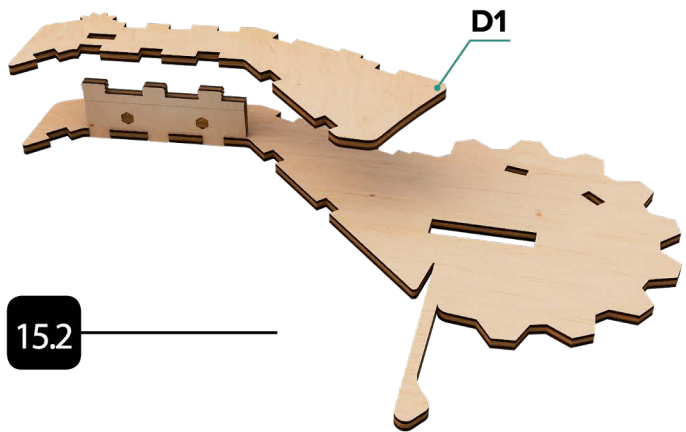
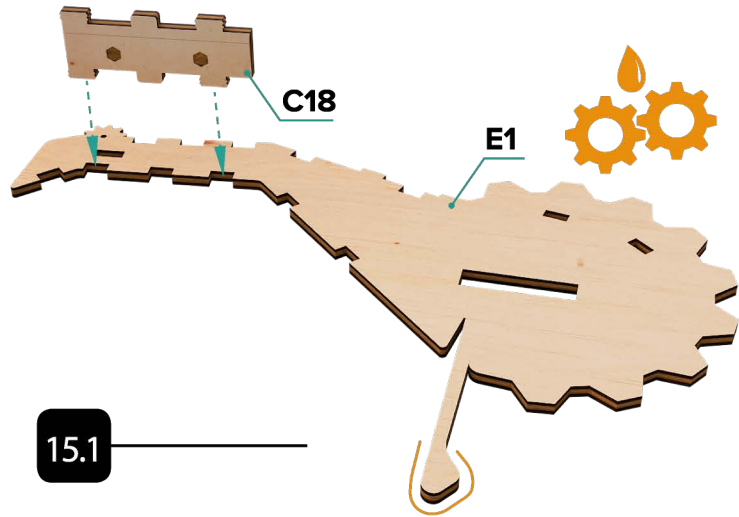

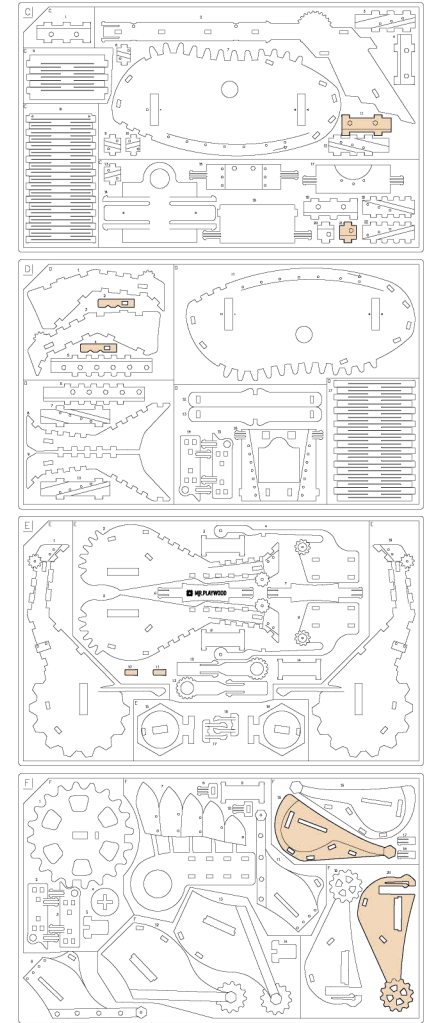
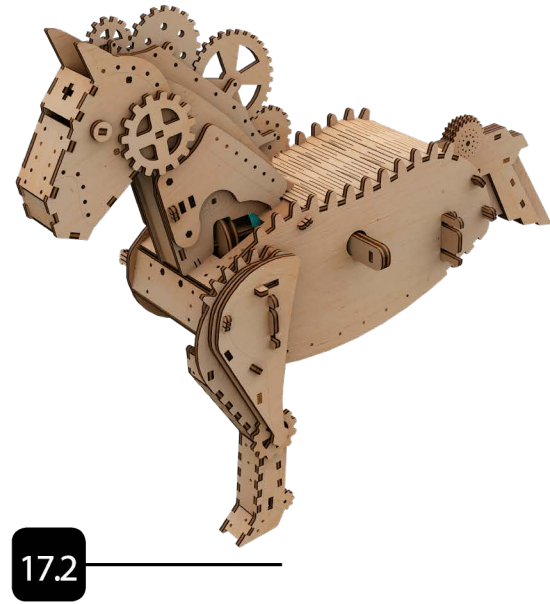
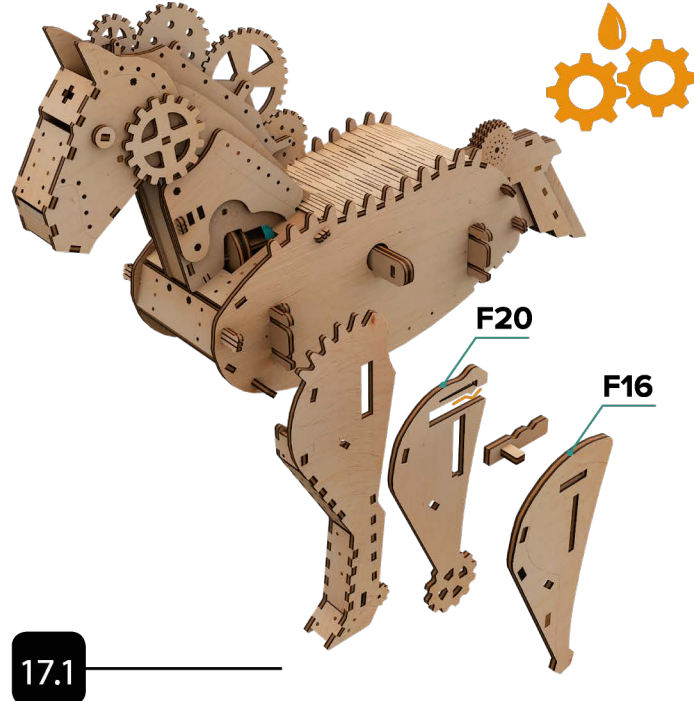
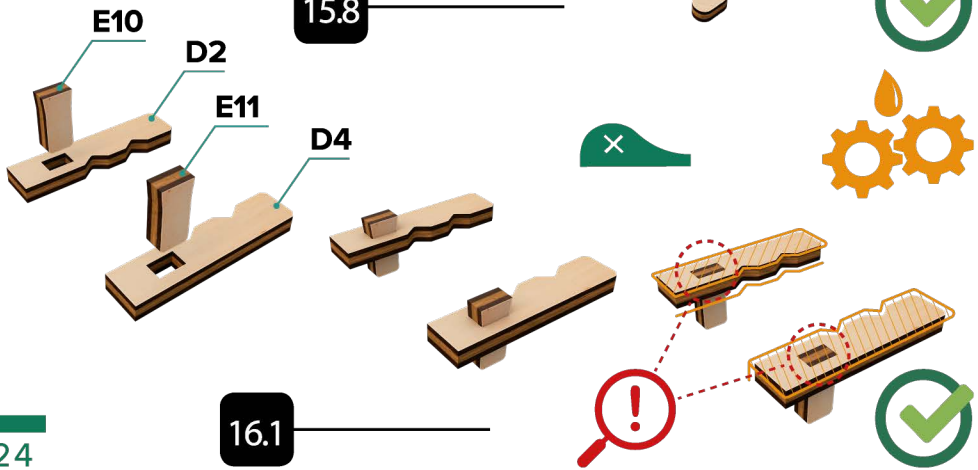
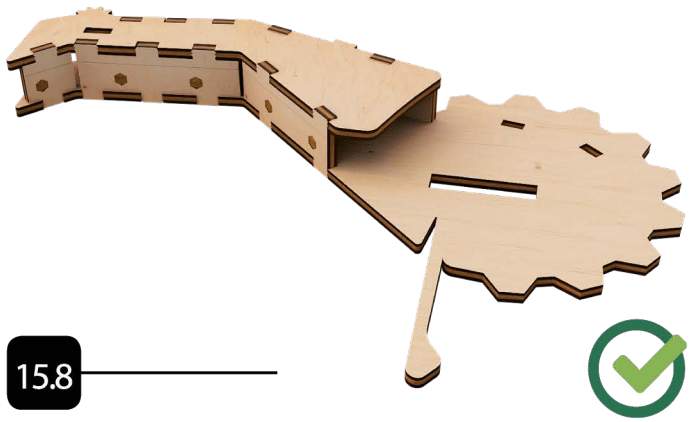
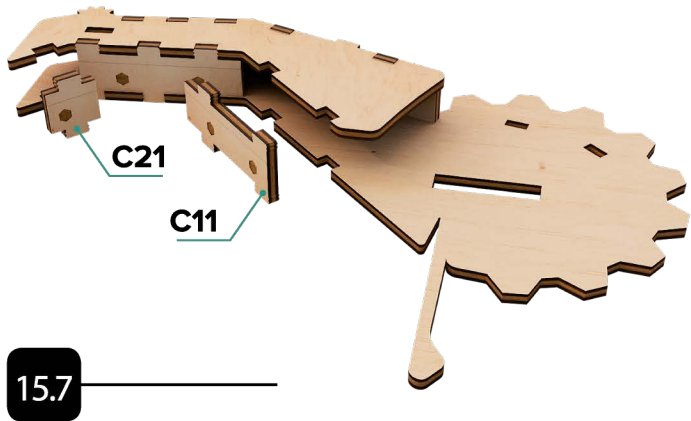



MR.  
PLAY  
WOOD

GIFT FOR  
GIFTED

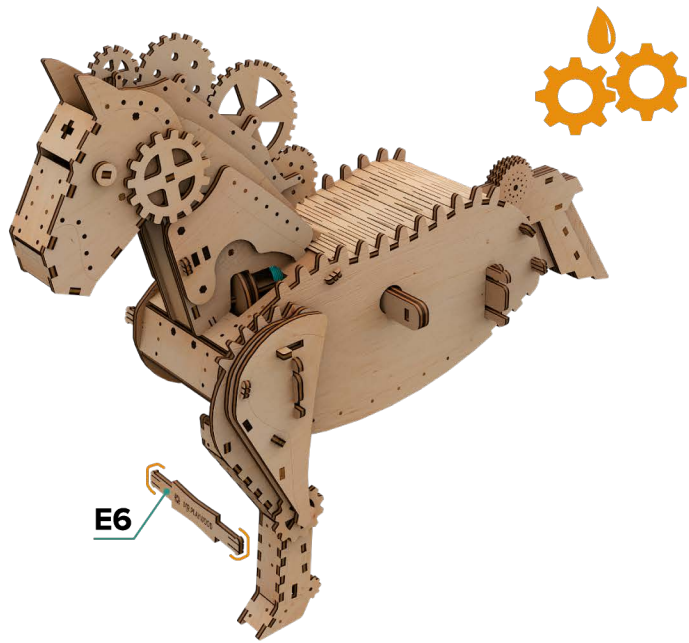

173

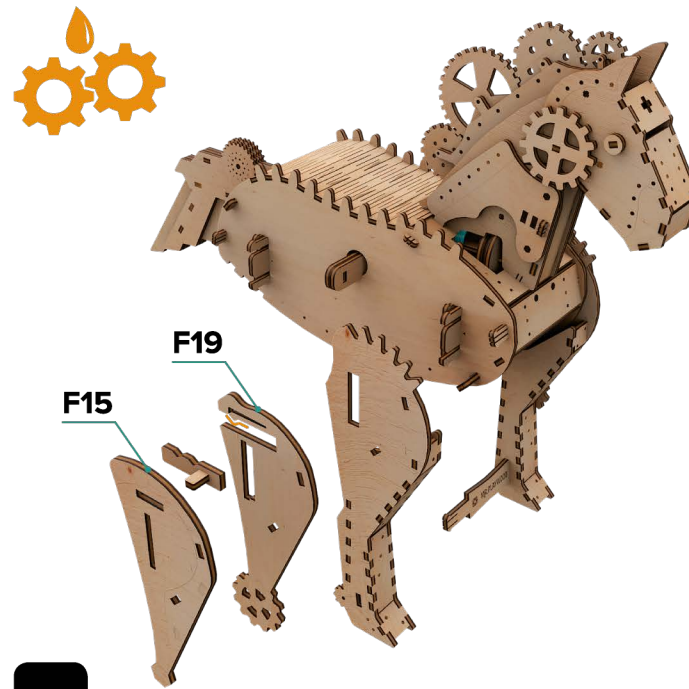

175

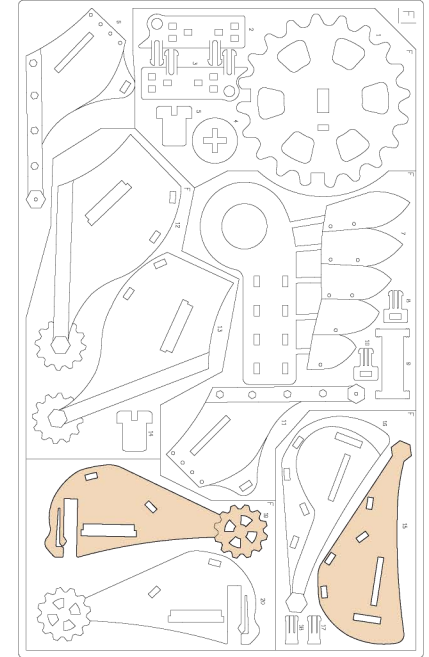
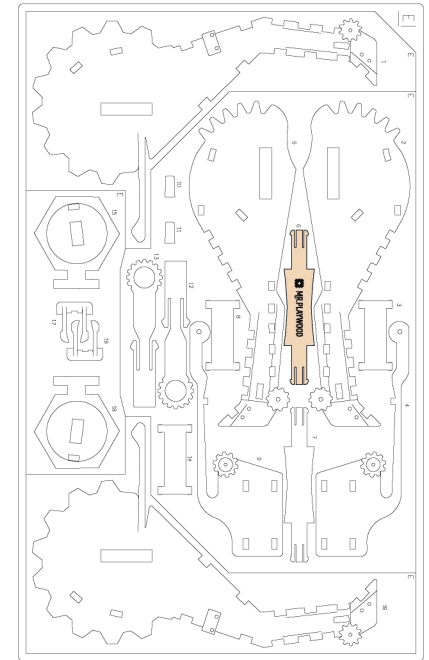
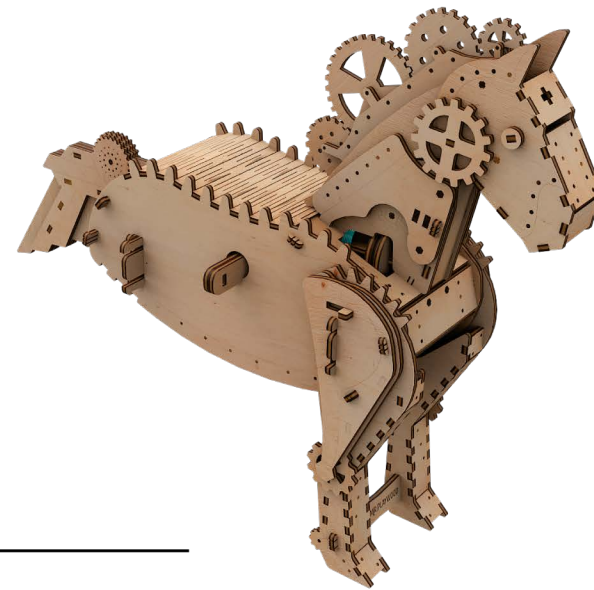



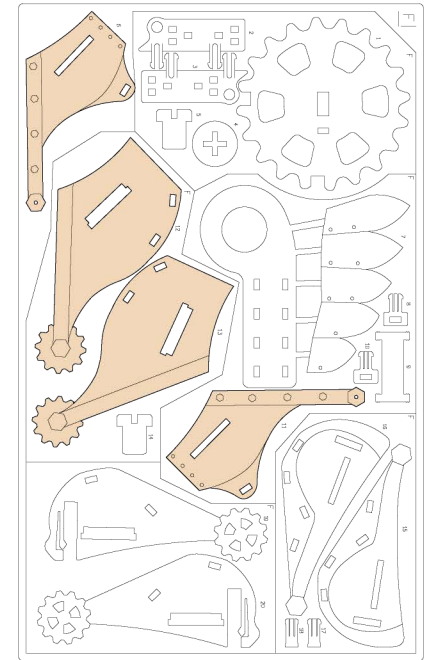
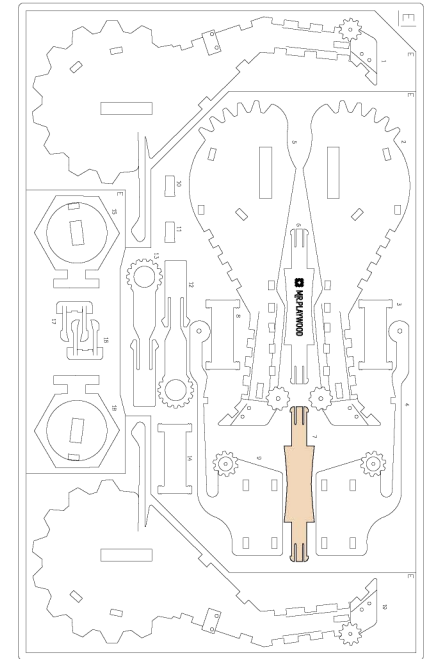
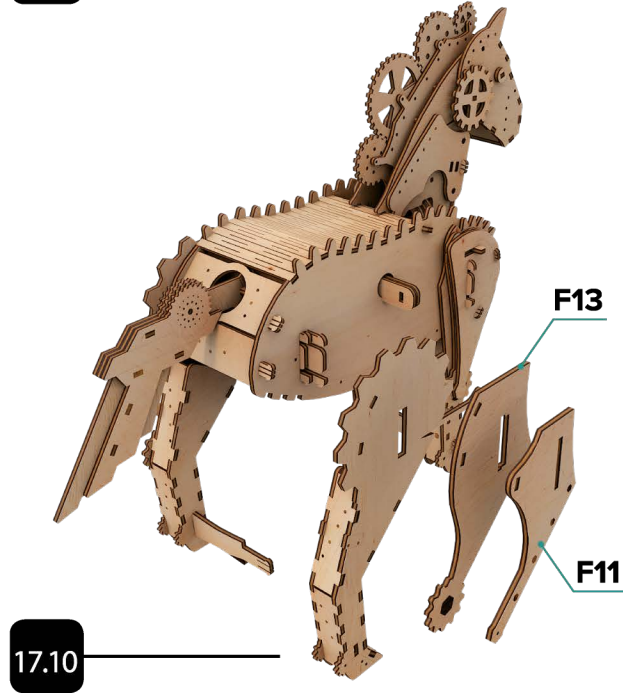
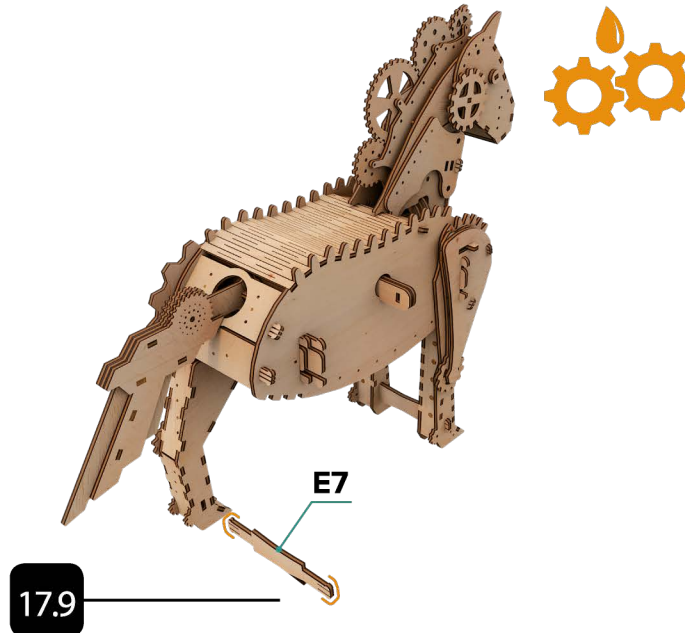
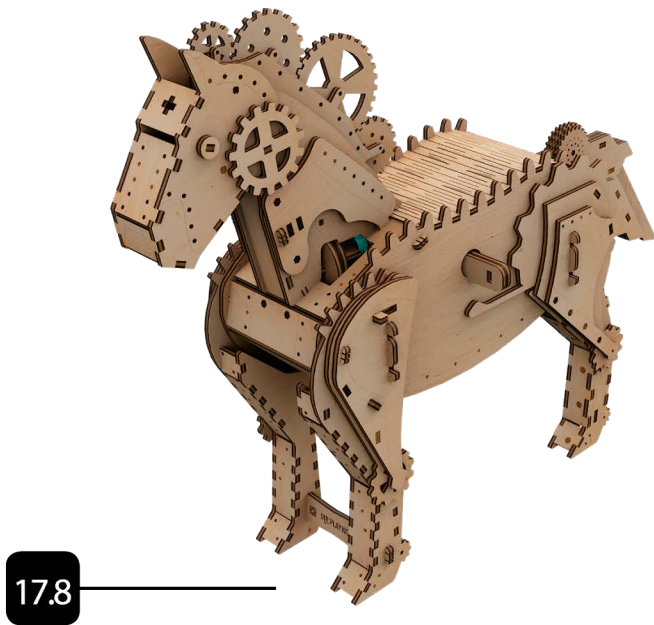
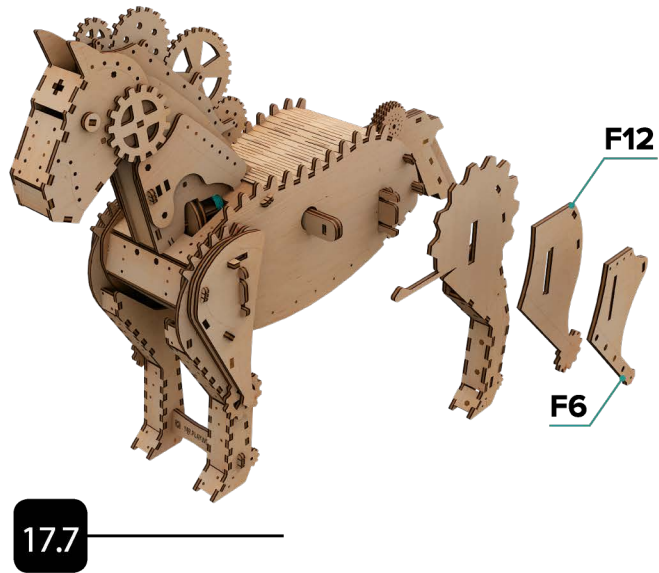

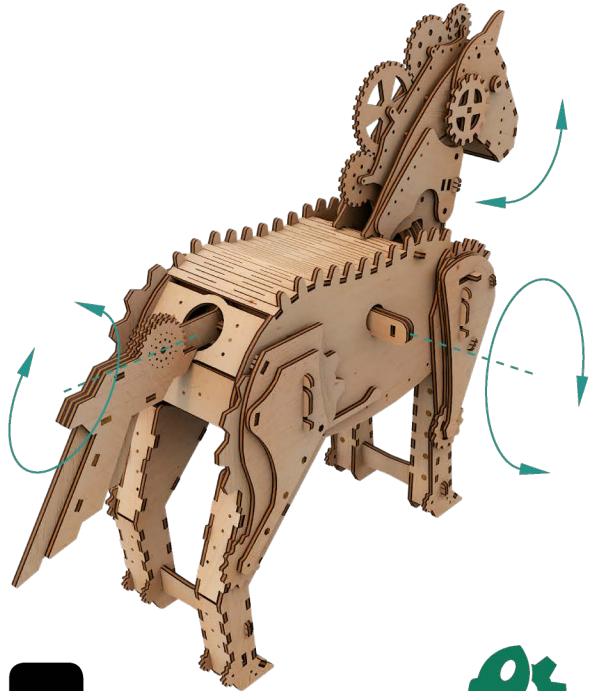

17.11

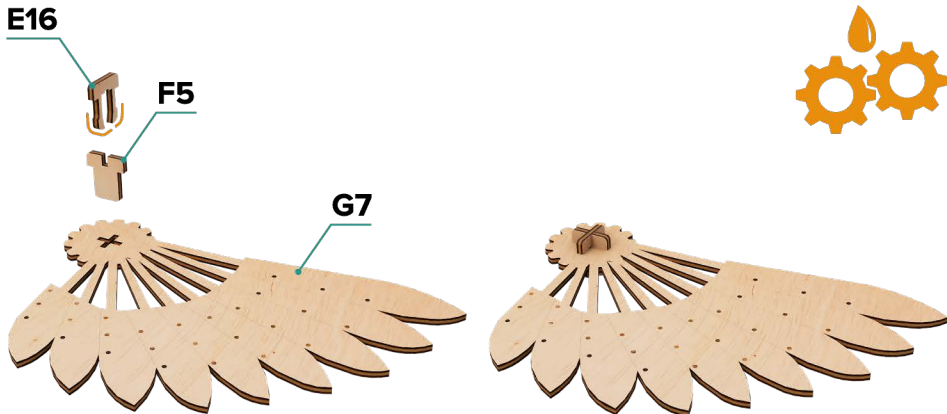

18.1

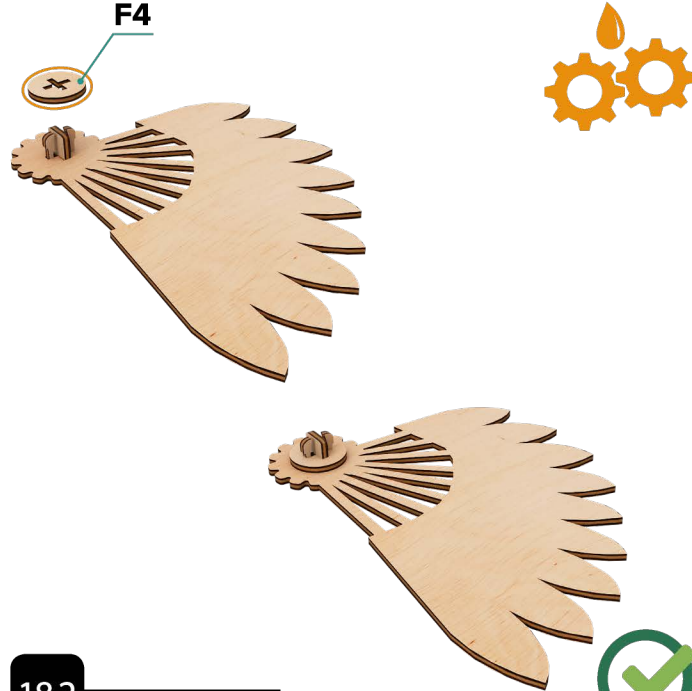

18.2

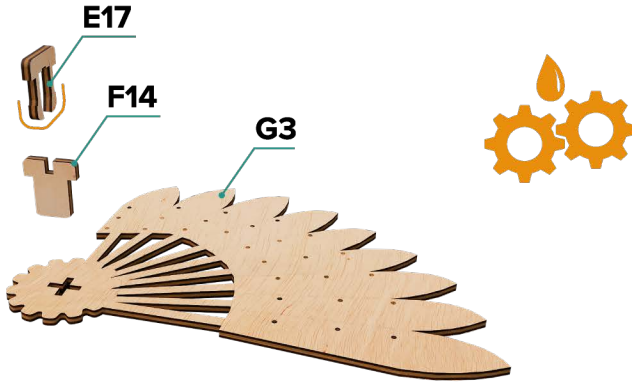

19.1

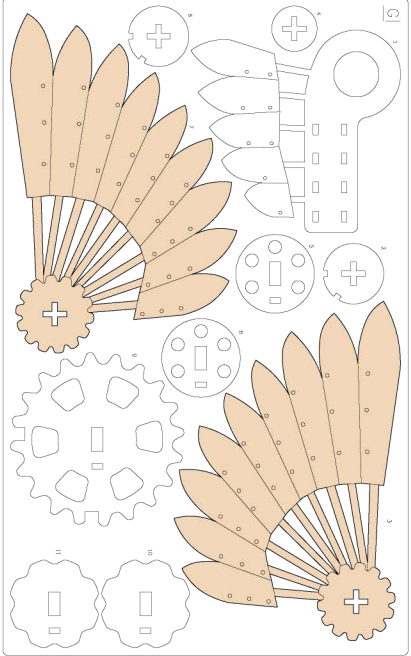
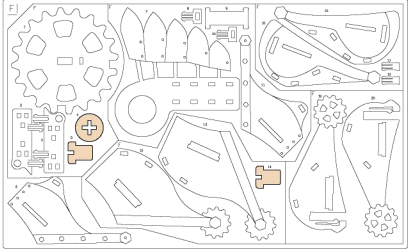
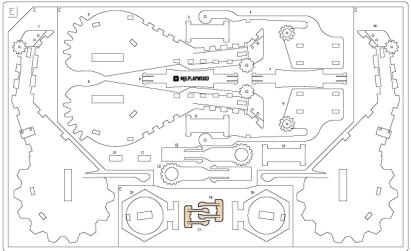

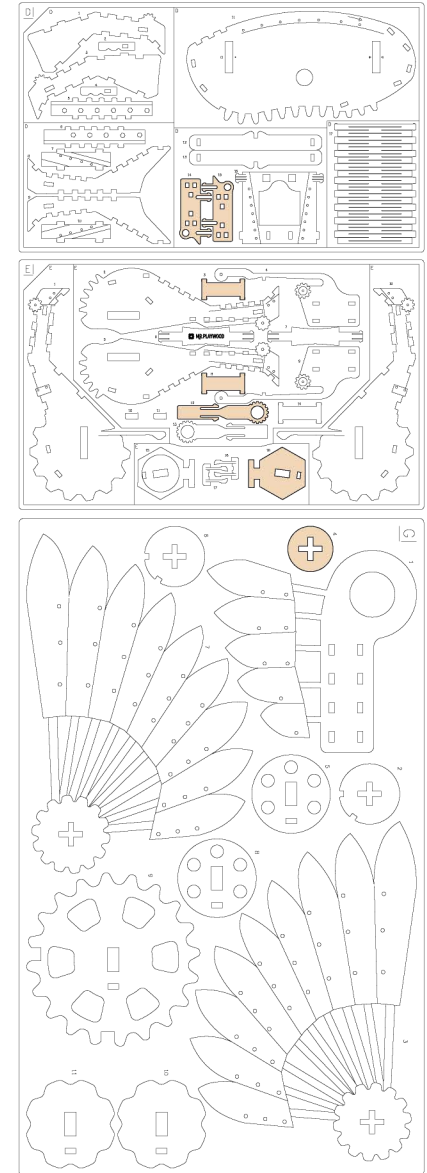
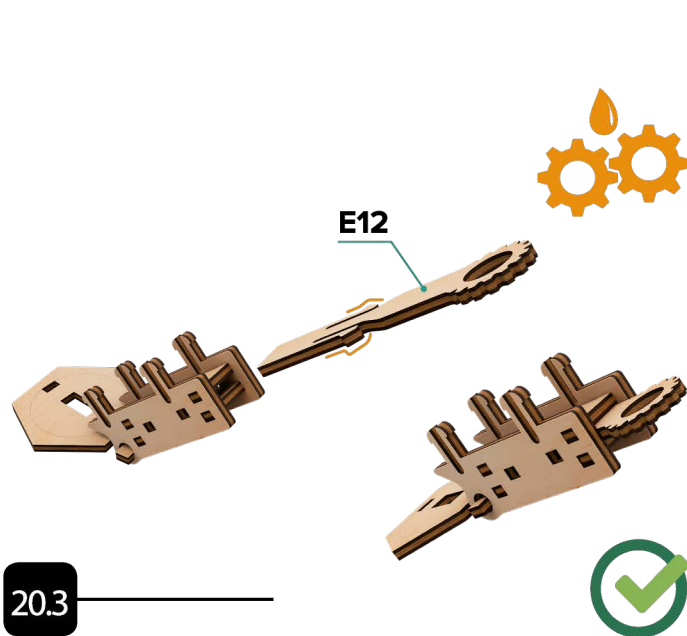
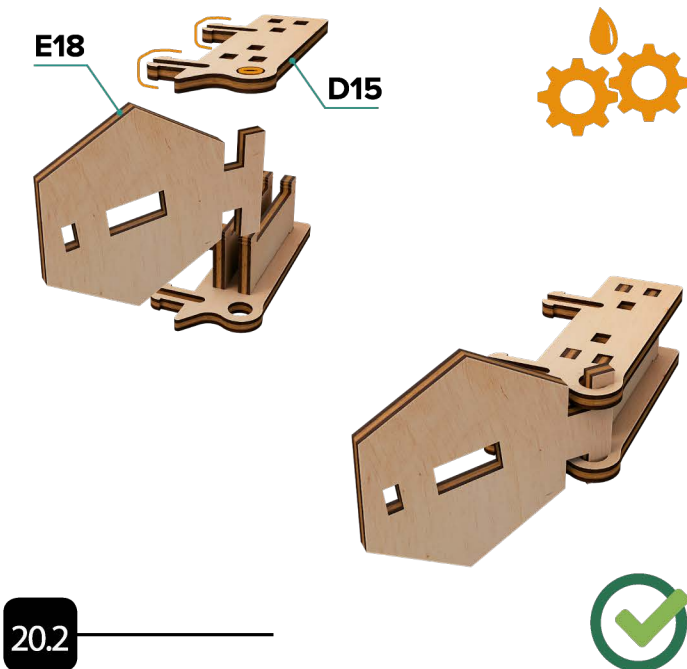
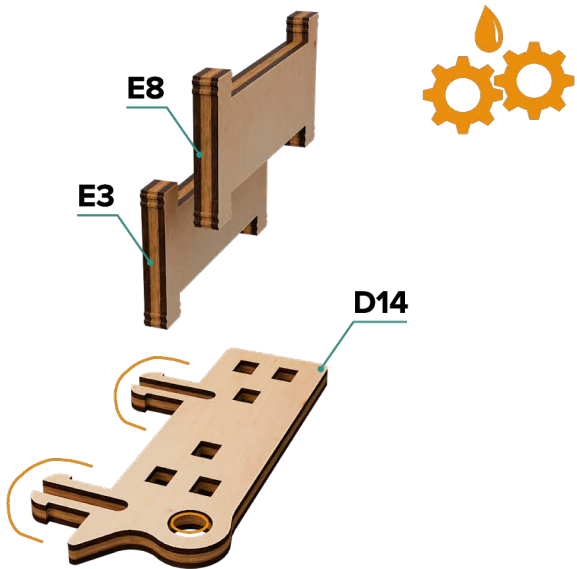
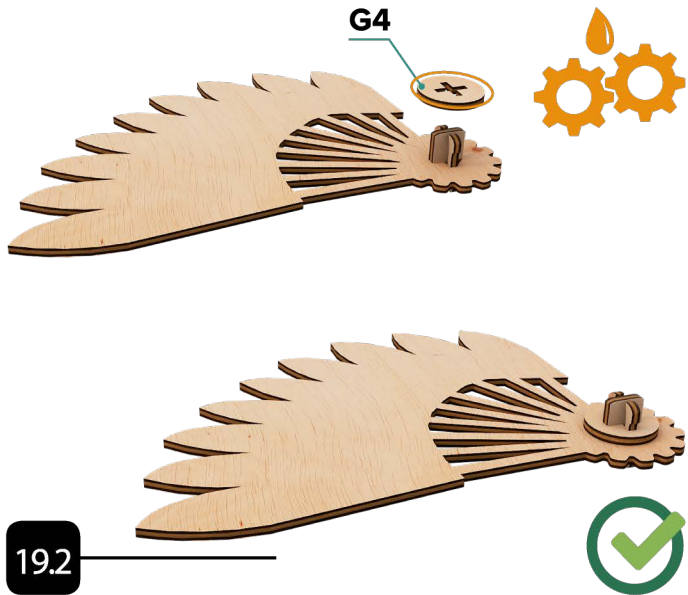



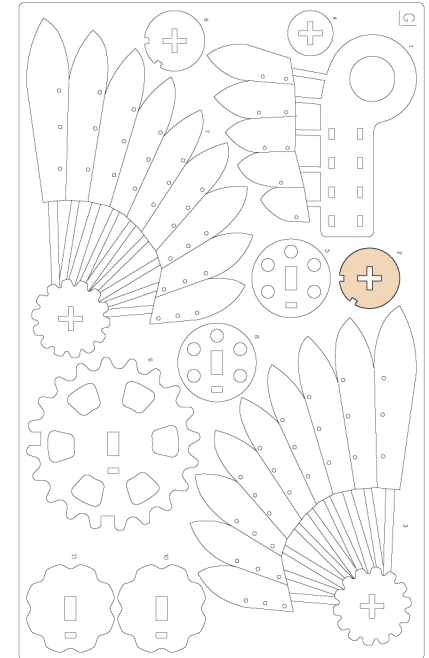
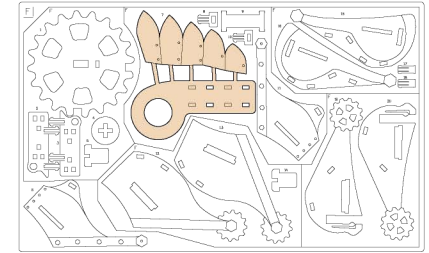
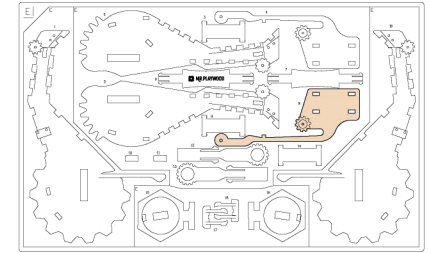
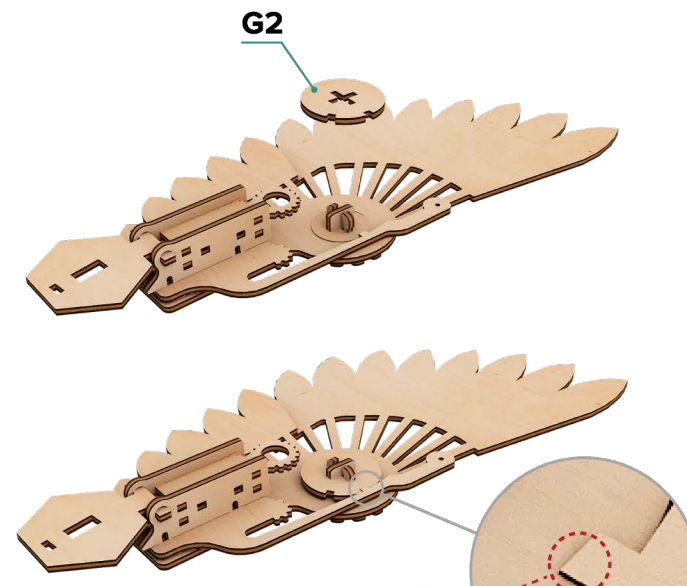
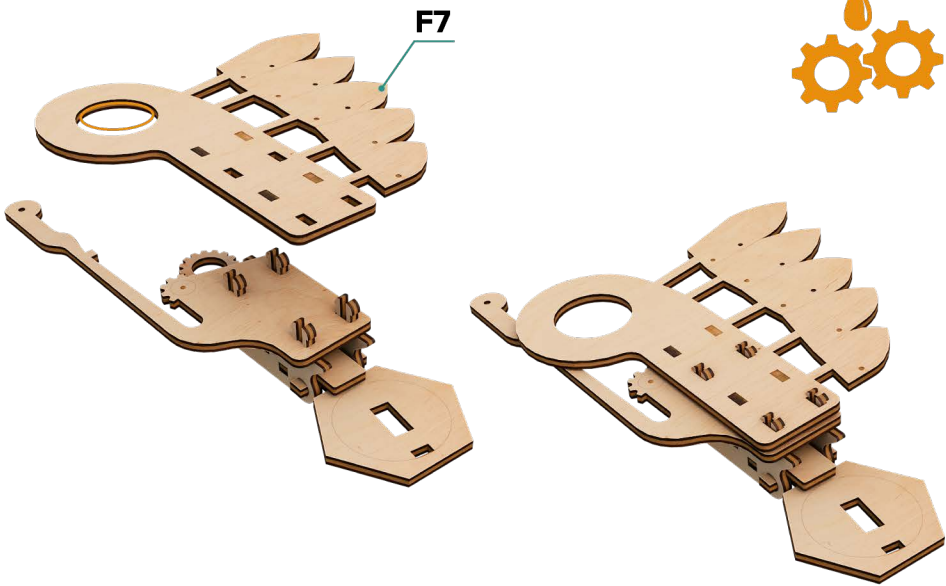
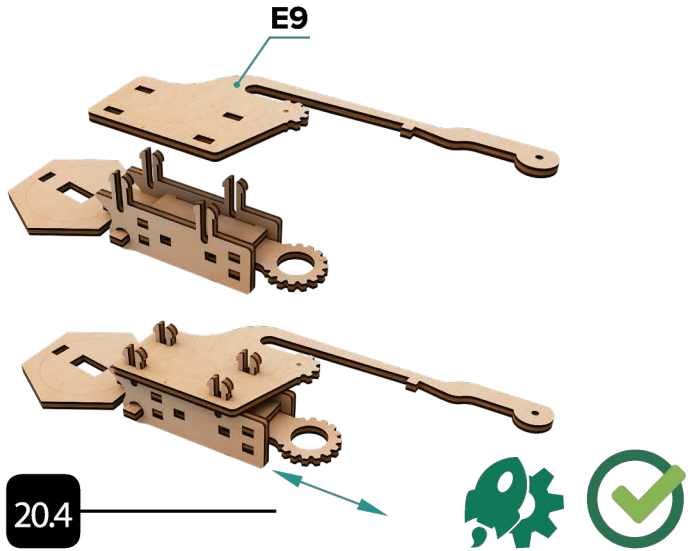

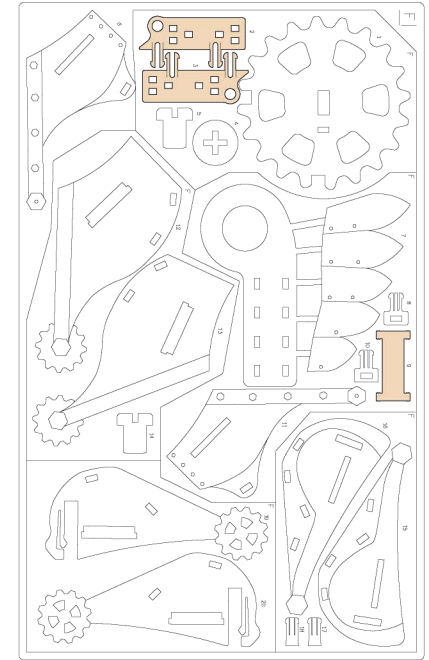
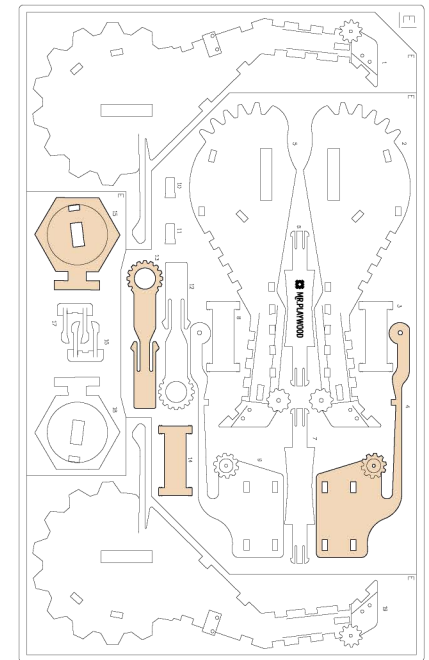
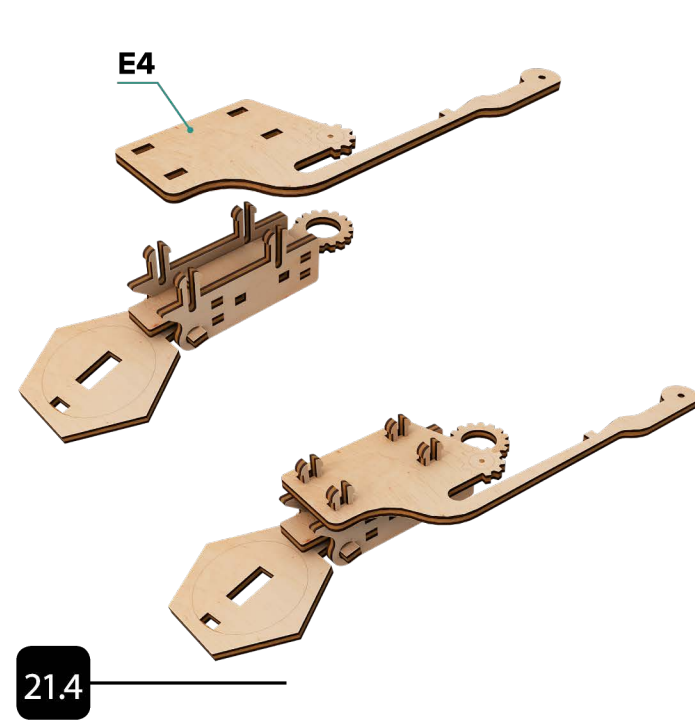
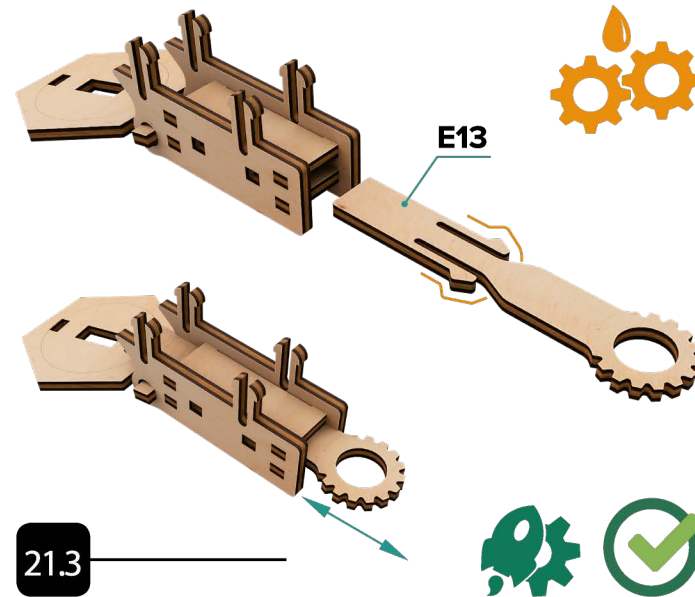
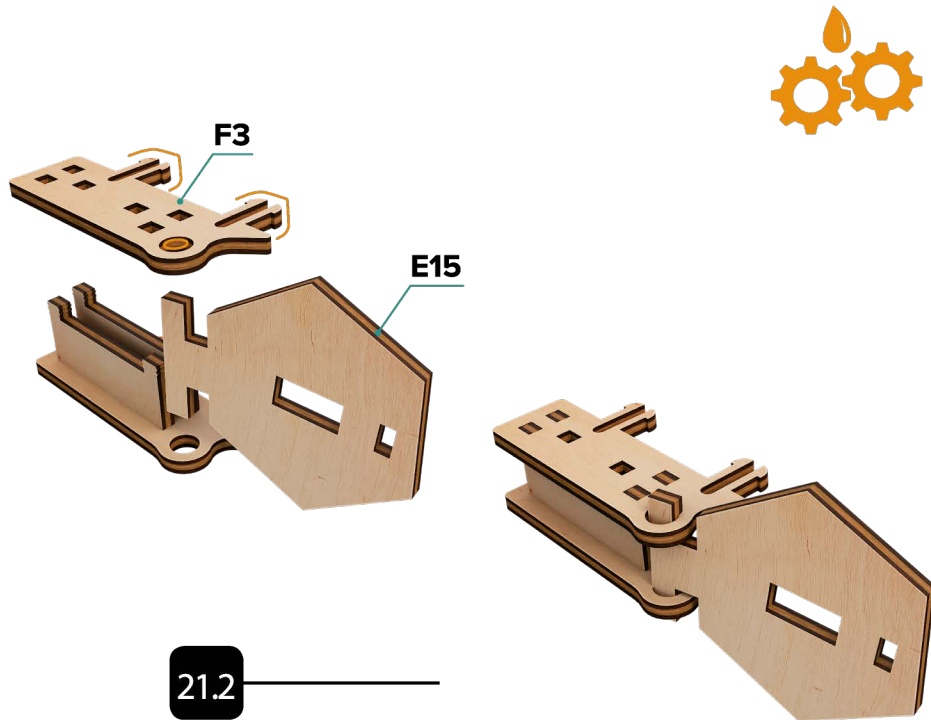
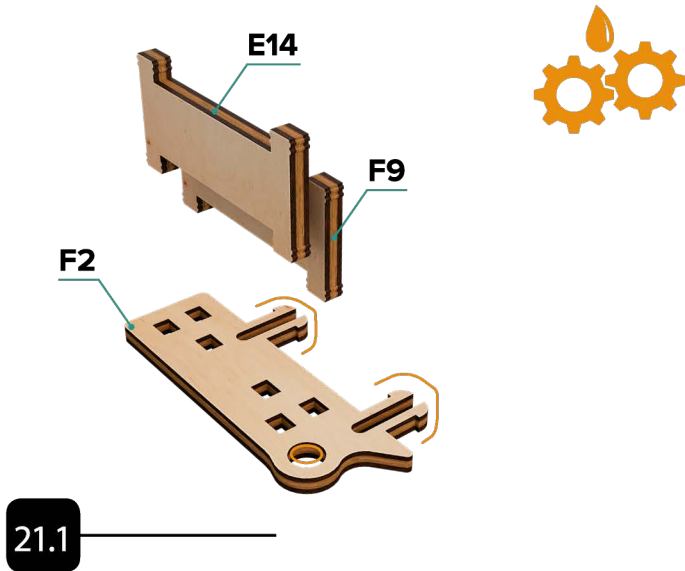



21.5

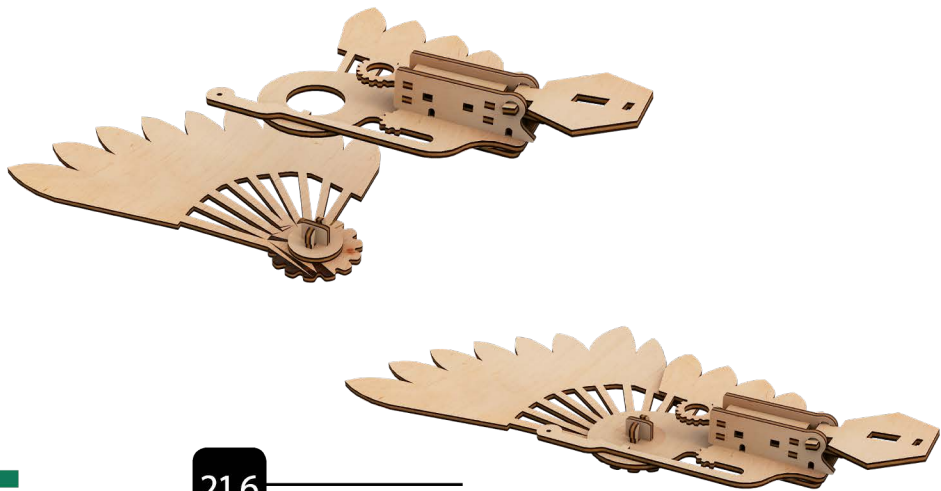

21.6

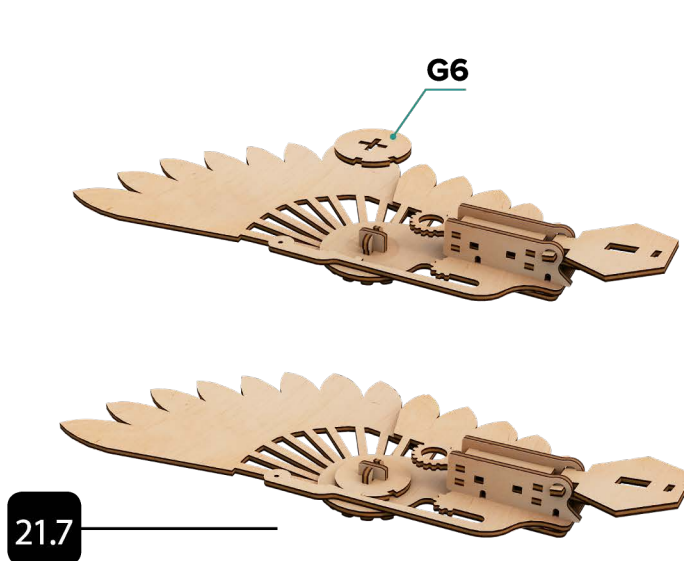

21.7

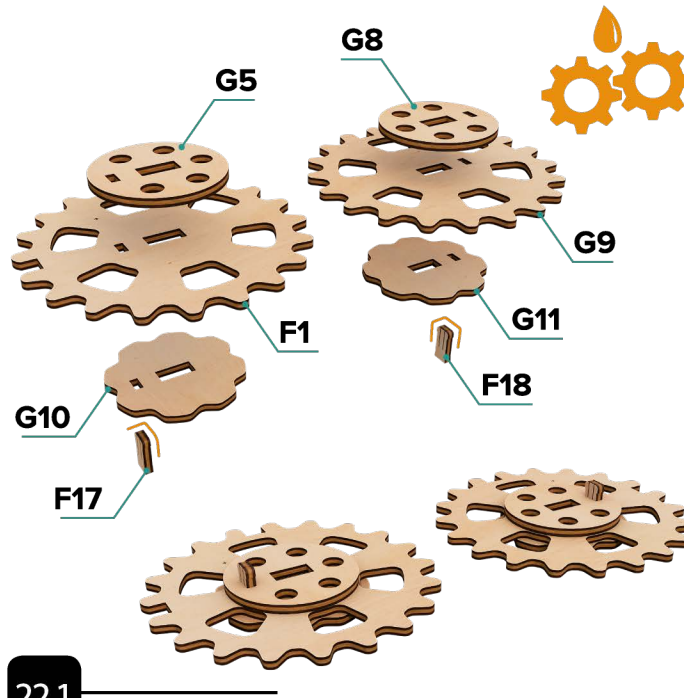

22.1

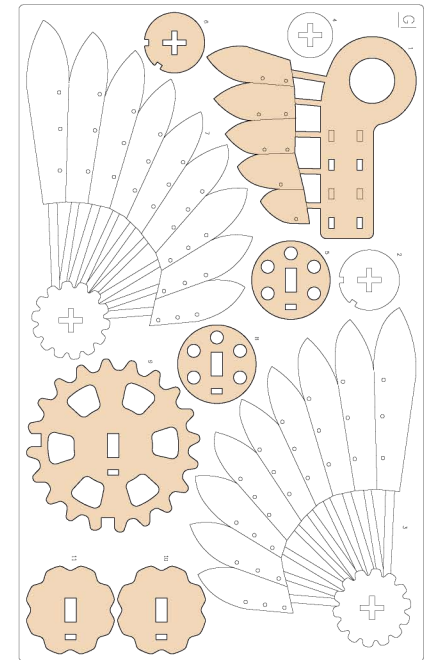
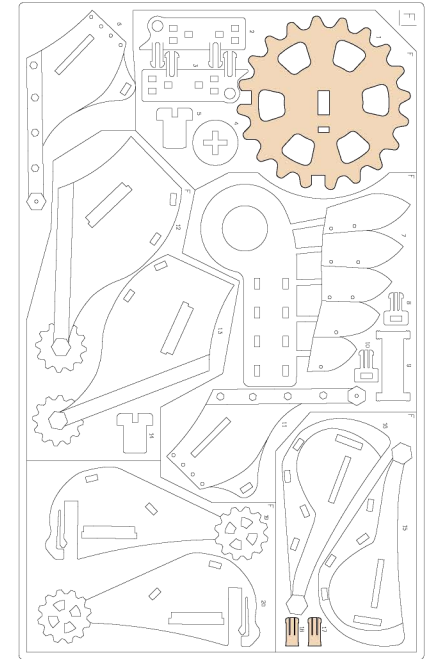





MR.  
PLAY  
WOOD  
GIFT FOR  
GIFTED



23.1



24.1

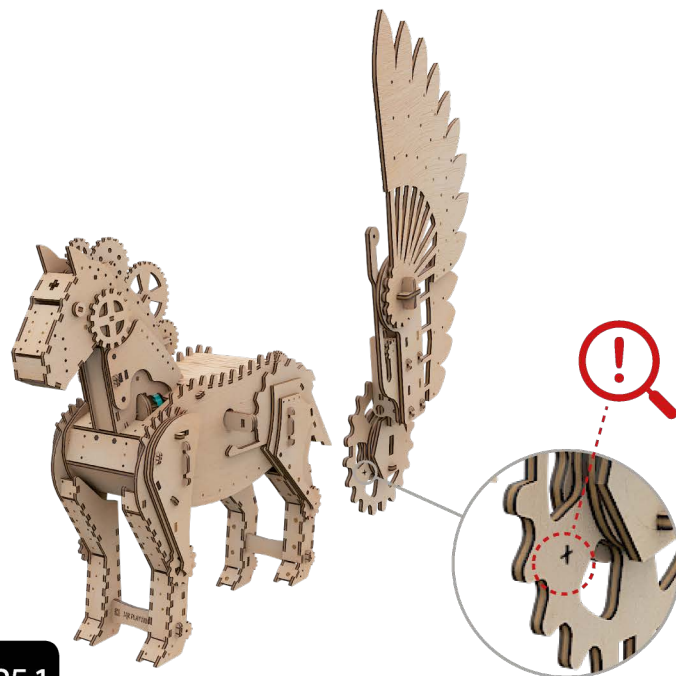

25.1

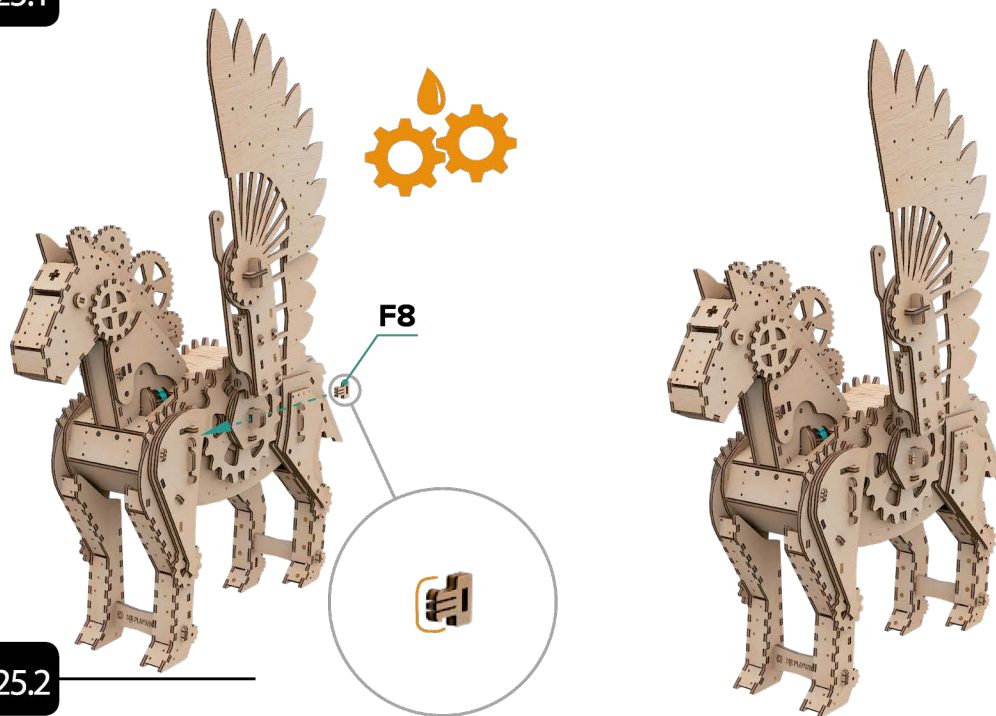
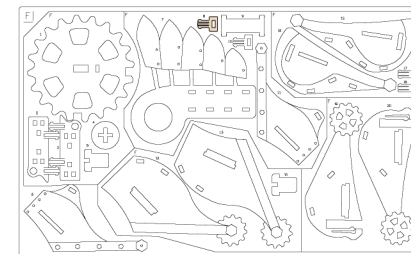

25.2



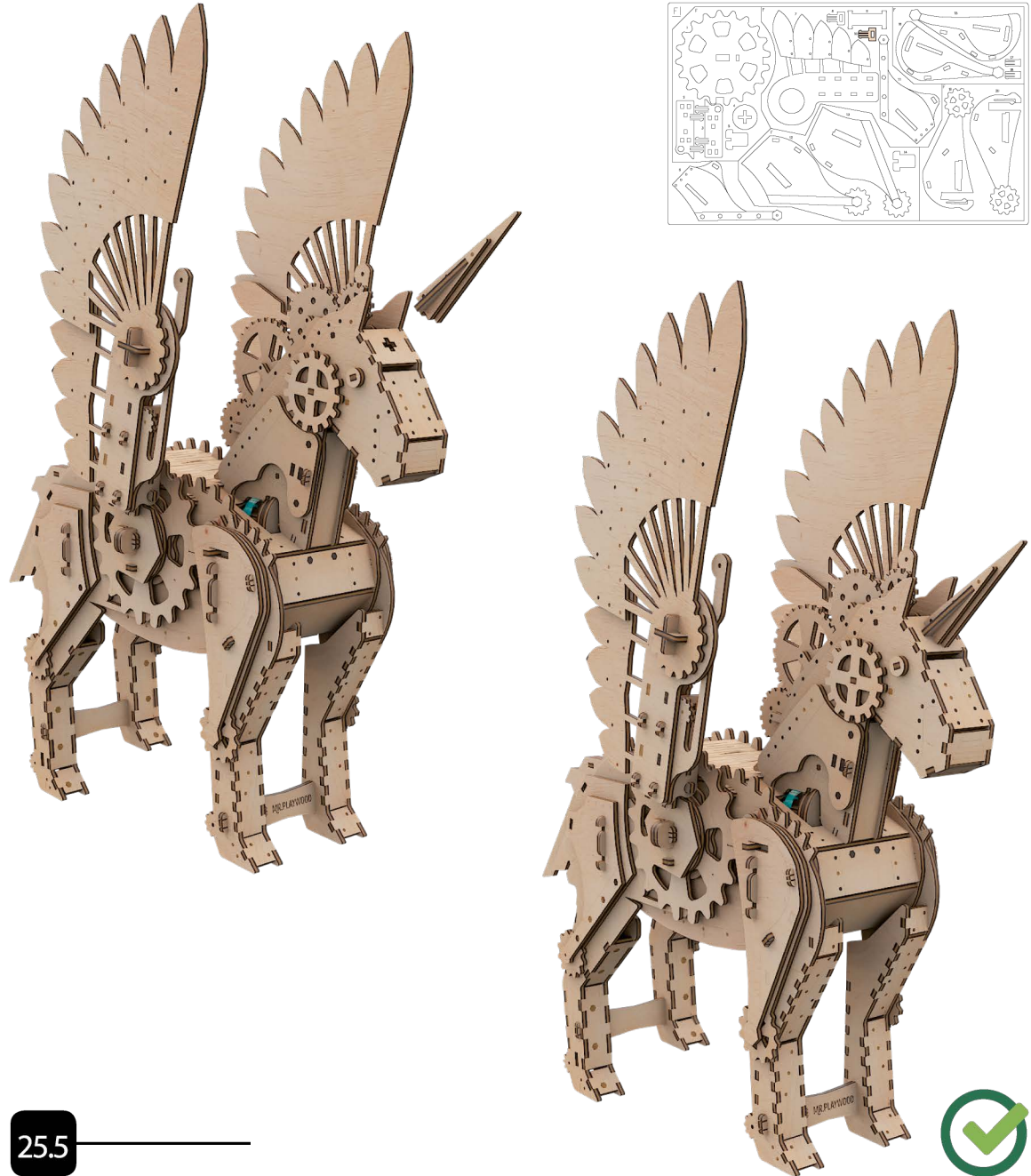
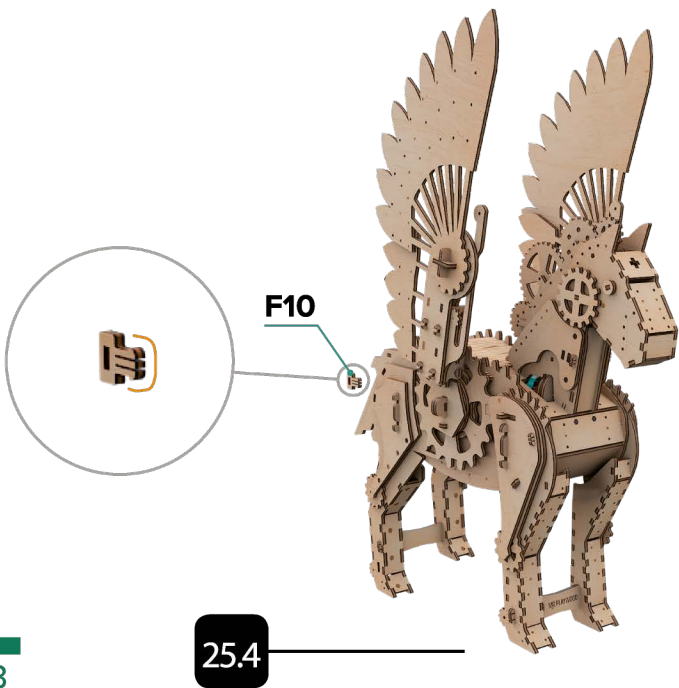
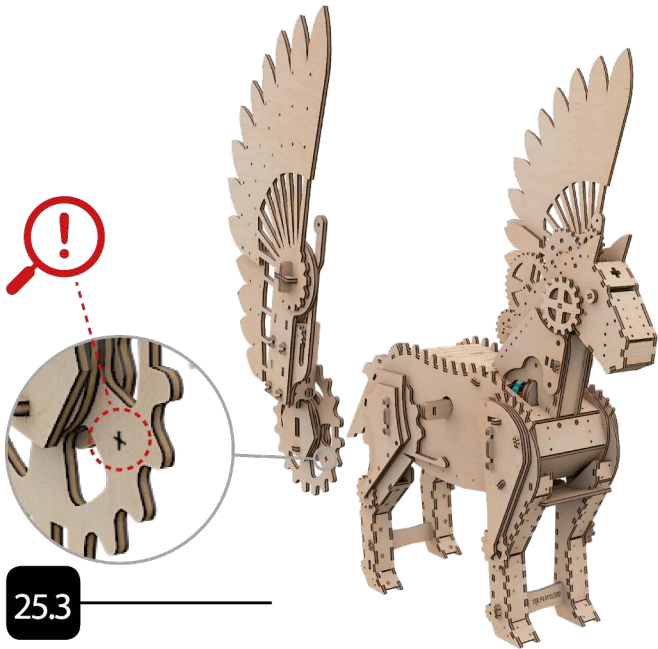





MR.  
PLAY  
WOOD

GIFT FOR  
GIFTED

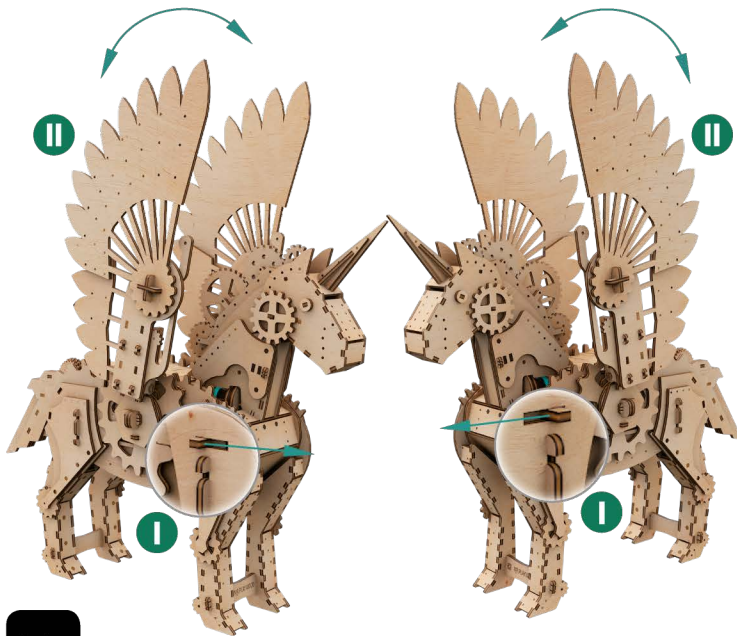

26.1



26.2

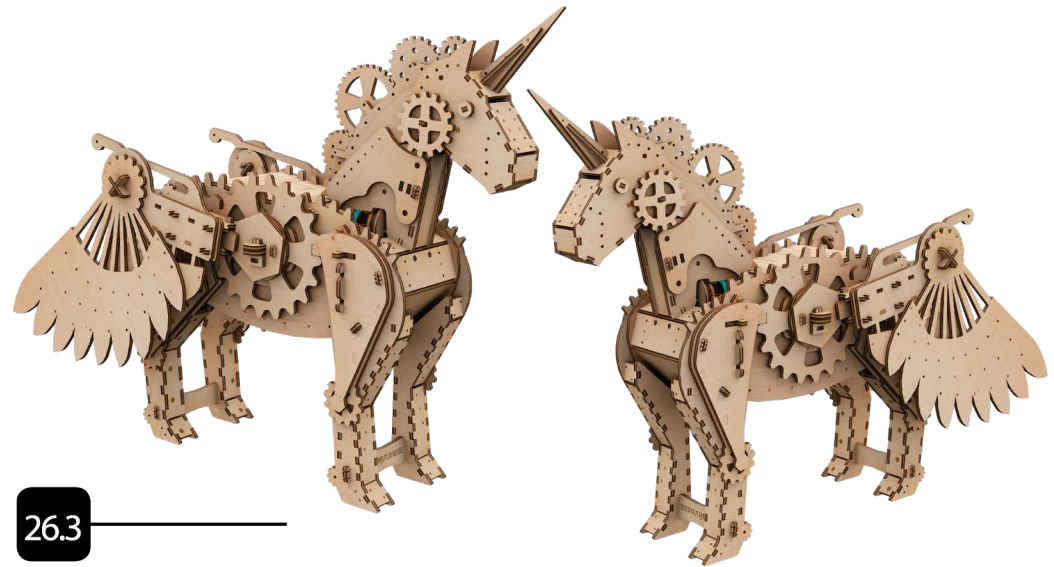

26.3

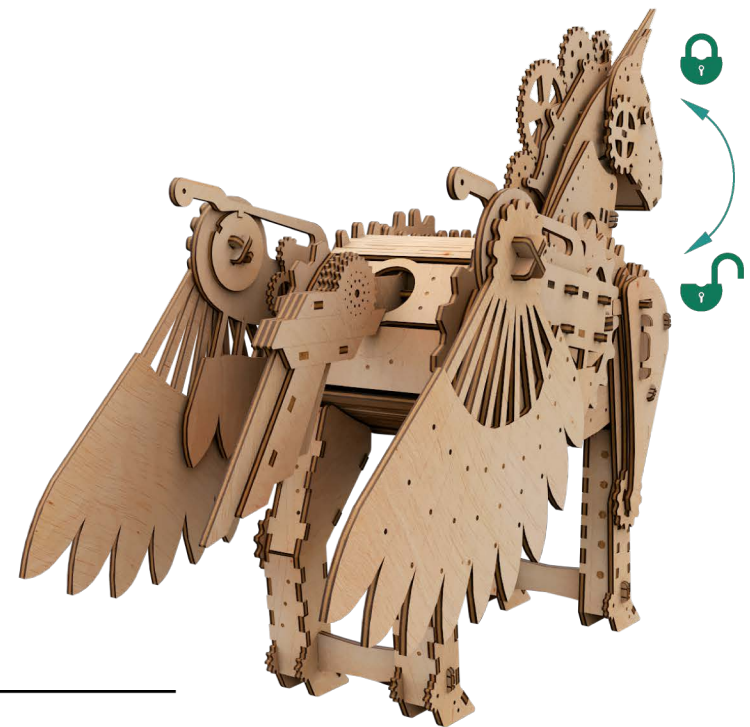

26.4





MR.  
PLAY  
WOOD

GIFT FOR  
GIFTED

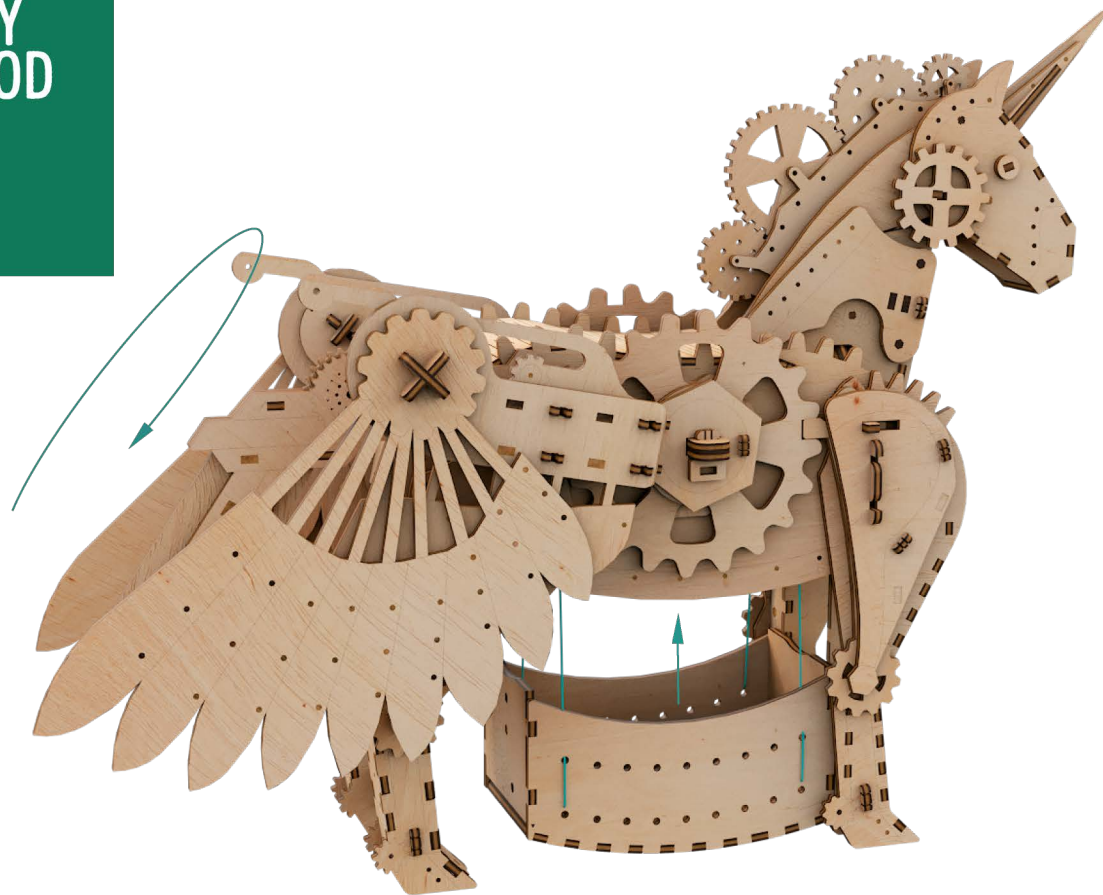

26.5

35

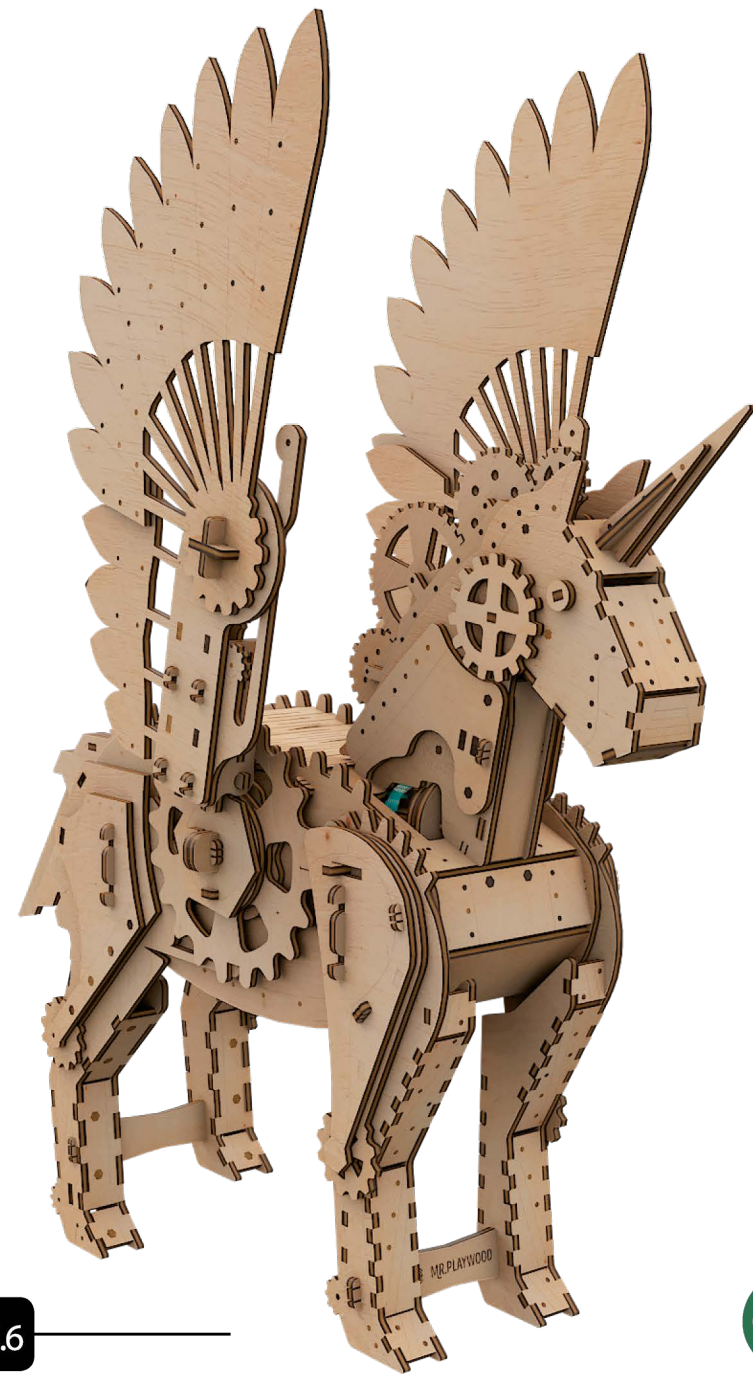

26.6



